

Keysight J-BERT M8020A High-Performance BERT and M8030A Multi-Channel BERT

Getting Started
Guide

Notices

© Keysight Technologies 2016

No part of this manual may be reproduced in any form or by any means (including electronic storage and retrieval or translation into a foreign language) without prior agreement and written consent from Keysight Technologies as governed by United States and international copyright laws.

Trademarks

PCI Express® and PCIe® are registered trademarks of PCI-SIG.

Manual Part Number

M8020-91020

Edition

Edition 5.1, March 2016

Printed in Malaysia

Keysight Technologies Deutschland GmbH
Herrenberger Strasse 130,
71034 Böblingen, Germany

Technology Licenses

The hardware and/or software described in this document are furnished under a license and may be used or copied only in accordance with the terms of such license.

U.S. Government Rights

The Software is “commercial computer software,” as defined by Federal Acquisition Regulation (“FAR”) 2.101. Pursuant to FAR 12.212 and 27.405-3 and Department of Defense FAR Supplement

(“DFARS”) 227.7202, the U.S. government acquires commercial computer software under the same terms by which the software is customarily provided to the public. Accordingly, Keysight provides the Software to U.S. government customers under its standard commercial license, which is

embodied in its End User License Agreement (EULA), a copy of which can be found at <http://www.keysight.com/find/sweula>. The license set forth in the EULA represents the exclusive authority by which the U.S. government may use, modify, distribute, or disclose the Software. The EULA and the license set forth therein, does not require or permit, among other things, that Keysight: (1) Furnish technical information related to commercial computer software or commercial computer software documentation that is not customarily provided to the public; or (2) Relinquish to, or otherwise provide, the government rights in excess of these rights customarily provided to the public to use, modify, reproduce, release, perform, display, or disclose commercial computer software or commercial computer software documentation. No additional government requirements beyond those set forth in the EULA shall apply, except to the extent that those terms, rights, or licenses are explicitly required from all providers of commercial computer software pursuant to the FAR and the DFARS and are set forth specifically in writing elsewhere in the EULA. Keysight shall be under no obligation to update, revise or otherwise modify the Software. With respect to any technical data as defined by FAR 2.101, pursuant to FAR 12.211 and 27.404.2 and DFARS 227.7102, the U.S. government acquires no greater than Limited Rights as defined in FAR 27.401 or DFAR 227.7103-5 (c), as applicable in any technical data.

Warranty

THE MATERIAL CONTAINED IN THIS DOCUMENT IS PROVIDED “AS IS,” AND IS SUBJECT TO BEING CHANGED, WITHOUT NOTICE, IN FUTURE EDITIONS. FURTHER, TO THE MAXIMUM EXTENT PERMITTED BY APPLICABLE LAW, KEYSIGHT DISCLAIMS ALL WARRANTIES, EITHER EXPRESS OR IMPLIED WITH REGARD TO THIS MANUAL

AND ANY INFORMATION CONTAINED HEREIN, INCLUDING BUT NOT LIMITED TO THE IMPLIED WARRANTIES OF MERCHANTABILITY AND FITNESS FOR A PARTICULAR PURPOSE. KEYSIGHT SHALL NOT BE LIABLE FOR ERRORS OR FOR INCIDENTAL OR CONSEQUENTIAL DAMAGES IN CONNECTION WITH THE FURNISHING, USE, OR PERFORMANCE OF THIS DOCUMENT OR ANY INFORMATION CONTAINED HEREIN. SHOULD KEYSIGHT AND THE USER HAVE A SEPARATE WRITTEN AGREEMENT WITH WARRANTY TERMS COVERING THE MATERIAL IN THIS DOCUMENT THAT CONFLICT WITH THESE TERMS, THE WARRANTY TERMS IN THE SEPARATE AGREEMENT WILL CONTROL.

Safety Notices

CAUTION

A CAUTION notice denotes a hazard. It calls attention to an operating procedure, practice, or the like that, if not correctly performed or adhered to, could result in damage to the product or loss of important data. Do not proceed beyond a CAUTION notice until the indicated conditions are fully understood and met.

WARNING

A WARNING notice denotes a hazard. It calls attention to an operating procedure, practice, or the like that, if not correctly performed or adhered to, could result in personal injury or death. Do not proceed beyond a WARNING notice until the indicated conditions are fully understood and met.

Safety Summary



The following general safety precautions must be observed during all phases of operation of this instrument. Failure to comply with these precautions or with specific warnings or operating instructions in the product manuals violates safety standards of design, manufacture, and intended use of the instrument. Keysight Technologies assumes no liability for the customer's failure to comply with these requirements. Product manuals are provided with your instrument on CD-ROM and/or in printed form. Printed manuals are an option for many products. Manuals may also be available on the Web. Go to www.keysight.com and type in your product number in the Search field at the top of the page.

General	<p>This product is a Safety Class 1 instrument (provided with a protective earth terminal). The protective features of this product may be impaired if it is used in a manner not specified in the operation instructions.</p> <p>All Light Emitting Diodes (LEDs) used in this product are Class 1 LEDs as per IEC 60825-1.</p>
Environment Conditions	<p>This instrument is intended for indoor use in an installation category II, pollution degree 2 environment. It is designed to operate at a maximum relative humidity of 95% and at altitudes of up to 2000 meters.</p> <p>Refer to the specifications tables for the ac mains voltage requirements and ambient operating temperature range.</p>
Before Applying Power	<p>Verify that all safety precautions are taken. The power cable inlet of the instrument serves as a device to disconnect from the mains in case of hazard. The instrument must be positioned so that the operator can easily access the power cable inlet. When the instrument is rack mounted the rack must be provided with an easily accessible mains switch.</p>
Ground the Instrument	<p>To minimize shock hazard, the instrument chassis and cover must be connected to an electrical protective earth ground. The instrument must be connected to the ac power mains through a grounded power cable, with the ground wire firmly connected to an electrical ground (safety ground) at the power outlet. Any interruption of the protective (grounding) conductor or disconnection of the protective earth terminal will cause a potential shock hazard that could result in personal injury.</p>
Do Not Operate in an Explosive Atmosphere	<p>Do not operate the instrument in the presence of flammable gases or fumes.</p>
Do Not Remove the Instrument Cover	<p>Operating personnel must not remove instrument covers. Component replacement and internal adjustments must be made only by qualified personnel.</p> <p>Instruments that appear damaged or defective should be made inoperative and secured against unintended operation until they can be repaired by qualified service personnel.</p>

Safety Symbols

Table 1 Safety Symbol

Symbol	Description
	Indicates warning or caution. If you see this symbol on a product, you must refer to the manuals for specific Warning or Caution information to avoid personal injury or damage to the product.
	Frame or chassis ground terminal. Typically connects to the equipment's metal frame.
	KC is the Korean certification mark to demonstrate that the equipment is Class A suitable for professional use and is for use in electromagnetic environments outside of the home.
	Indicates that antistatic precautions should be taken.
	Indicates the time period during which no hazardous or toxic substance elements are expected to leak or deteriorate during normal use. Forty years is the expected useful life of the product.
	The RCM Mark is a compliance mark to the ACMA (Australian Spectrum Management Agency). This indicates compliance with all Australian EMC regulatory information.

Symbol	Description
	<p>CSA is the Canadian certification mark to demonstrate compliance with the Safety requirements.</p>
	<p>CE compliance marking to the EU Safety and EMC Directives. ISM GRP-1A classification according to the international EMC standard. ICES/NMB-001 compliance marking to the Canadian EMC standard.</p>
	<p>This symbol on all primary and secondary packaging indicates compliance to China standard GB 18455-2001.</p>

Compliance and Environmental Information

Table 2 Compliance and Environmental Information

Safety Symbol	Description
	<p>This product complies with WEEE Directive (2002/96/EC) marking requirements. The affixed label indicates that you must not discard this electrical/electronic product in domestic household waste.</p> <p>Product Category: With reference to the equipment types in WEEE Directive Annex I, this product is classed as a “Monitoring and Control instrumentation” product.</p> <p>Do not dispose in domestic household waste.</p> <p>To return unwanted products, contact your local Keysight office, or see http://about.keysight.com/en/companyinfo/environment/takeback.shtml for more information.</p>

About This Guide

This guide provides high-level information for an initial setup of the Keysight J-BERT M8020A High-Performance BERT and M8030A Multi-Channel BERT. This guide focuses on setting up “bundled” systems such as the M8020A-BU1, M8020A-BU2, M8030A-BU1 and M8030A-BU2.

The M8020A-BU1 system has the M8000 module(s), M9536A AXIe Embedded Host Computer, M8070A software plus license, and module licenses pre-installed.

The M8030A-BU1 system has the M8000 module(s), M9514A AXIe Embedded Host Computer, M8070A software plus license, and module licenses pre-installed.

The M8020A-BU2 and M8030A-BU2 bundled systems has the M8000 module(s) and their licenses pre-installed but will require host computer connection and M8070A software plus license installation. These procedures are located in this guide.

NOTE

Network licenses are not pre-installed on any system. If you plan to use the M8020A or M8030A system over a network, you must perform the network license installation procedures in this guide.

If you ordered a system that requires onsite installation of individual M8000 modules or the M9536A AXIe Embedded Host Computer into the M9505A or M9514A AXIe Chassis, refer to the *Keysight M8020A and M8030A Installation Guide* for detailed module-level installation instructions.

Contents

Safety Summary	3
Compliance and Environmental Information	6
About This Guide	7

1 Introduction

M8020A Modules	14
M9505A AXIe Chassis	14
M9505-00230 AXIe Embedded System Module (USB ESM)	15
Keysight M9536A AXIe Embedded Controller Module	16
M8030A Modules	17
M9514A AXIe Chassis	17
M9521A AXIe System Module (ASM)	19
Keysight M9536A AXIe Embedded Controller Module	20
J-BERT M8041A High-Performance BERT Generator-Analyzer-Clock Module	22
M8041A Features	22
M8041A Module Components	23
M8041A Front Panel Connector Inputs/Outputs	24
J-BERT M8051A High-Performance BERT Generator-Analyzer Module	27
M8051A Features	27
M8051A Module Components	27
M8051A Front Panel Connector Inputs/Outputs	29
M8061A 32 Gb/s Multiplexer with De-emphasis Module	31
M8061A Features	31
M8061A Module Components	32
M8061A Front Panel Connector Inputs/Outputs	33

M8062A 32Gb/s Front-end for J-BERT M8020A High-Performance BERT 35

M8062A Features 35

M8062A Module Components 36

M8062A Front Panel Pattern Generator Connectors 37

M8062A Front Panel Analyzer Connectors 38

M8192A Multi-Channel Synchronization Module 40

Host Computer 40

2 Basic Setup for M8020A

Step 1 - Unpack the Shipment 42

Return the Damaged/Defective Item to Keysight for Repair/Replacement 43

Step 2 - Set up the M8020A 43

Step 3 - Set up the External Host Computer (not required for M8020A-BU1) 43

Computer Hardware and Software Requirements 44

To connect via USB 45

To connect via PCIe 45

Step 4 - Connect the M9505A AXIe Chassis to a Power Supply 46

Step 5 - Power Up (if connecting via PCIe) 47

Step 6 - Verify Basic M8020A Operation 48

Step 7 - Install Keysight IO Libraries Suite (not required for M8020A-BU1) 49

Step 8 - Install M8070A Software (not required for M8020A-BU1) 49

Step 9 - Install the Licenses	50
Installing M8070A-OTP License (not required for M8020A-BU1)	51
Installing M8070A-ONP Floating/Networked License	51
Installing the FlexNet License Manager	53
Installing Module Licenses (for upgrades only)	59
Transporting an M8070A License	60
Affix Option Label (optional)	60
Step 10 - Turning off the Chassis and Modules	61
Step 11 - Connecting the M8020A to the Device Under Test (DUT)	61
Typical Test Setup Example	62
M9536A Embedded Controller Setup Example	63
M8061A Multiplexer Setup Example (32 Gb/s)	64
Hardware Connections	66
M8062A Setup Example (32 Gb/s)	70

3 Basic Setup for M8030A

Step 1 - Unpack the Shipment	74
Return the Damaged/Defective Item to Keysight for Repair/Replacement	75
Step 2 - Install the Chassis	75
Step 3 - Install the ASM in the Chassis	76
Step 4 - Power-Up and Power-Down the Chassis	76
To Power Up the Chassis	76
To Power Down the Chassis	77
Step 5 - M8030A Configuration	77
M8030A Modules Arrangement Example	78
Step 6 - Set up the Host PC (not required for M8030A-BU1)	79
Computer Hardware and Software Requirements	79
Step 7 - Power on the Chassis First then the Host Controller	80

Step 8 - Verify Basic M8030A Operation	81
Step 9 - Install Keysight IO Libraries Suite (not required for M8030A-BU1)	82
Step 10 - Install M8070A Software (not required for M8030A-BU1)	82
Step 11 - Install the Licenses	83

4 Using M8020A / M8030A

Locating Electronic Manuals and Online Help	86
Routine Care	86
Starting the M8070A Software	87
Perform a Measurement	88
M8061A/62A Configuration (Optional)	96
M8061A Configuration	96
M8062A Configuration	98
Updating Software Components	100
Contacting Keysight Service and Support	100
Quick Troubleshooting	100

Index

Keysight J-BERT M8020A High-Performance BERT and M8030A Multi-Channel BERT

Getting Started Guide

1

Introduction

M8020A Modules / 14

M8030A Modules / 17

J-BERT M8041A High-Performance BERT Generator-Analyzer-Clock Module / 22

J-BERT M8051A High-Performance BERT Generator-Analyzer Module / 27

M8061A 32 Gb/s Multiplexer with De-emphasis Module / 31

M8062A 32Gb/s Front-end for J-BERT M8020A High-Performance BERT / 35

M8192A Multi-Channel Synchronization Module / 40

This chapter introduces you to Keysight's J-BERT M8020A High-performance BERT and M8030A Multi-Channel BERT. It also introduces you to the concept of using a host computer to communicate with the M8020A and M8030A.

M8020A Modules

The M8020A modules are recognized by the model number and name located on their front panel.

Each of the supported modules has some standard hardware and software features that are available with a standard license for that module. Some upgraded features/components of a module are licensed and are only available when you purchase and install a license for that option.

The M8020A supports the following modules.

- M8041A high-performance BERT generator-analyzer-clock 8/16 Gb/s
- M8051A high-performance BERT generator-analyzer 8/16 Gb/s
- M8061A multiplexer 2:1 with de-emphasis 32 Gb/s
- M8062A 32Gb/s Front-end for J-BERT M8020A High-Performance BERT

The M8041A module must be installed in slots 1 through 3 in the AXIe chassis unless the M9536A AXIe Embedded Controller is installed. The M9536A AXIe Embedded Controller must be installed in slot 1.

The following configurations are possible in an M9505A 5-slot chassis:

- **1 or 2-channel, 16 Gb/s** - (1) M8041A
- **3 or 4-channel, 16 Gb/s** - (1) M8041A + (1) M8051A
- **1-channel, 32 Gb/s (Pattern Generator only)** - (1) M8041A + (1) M8061A
- **1-channel, 32 Gb/s (Pattern Generator only or full BERT)** - (1) M8041A + (1) M8062A

Details on the features and hardware components of each of the above mentioned modules are further described in this chapter.

M9505A AXIe Chassis

The M9505A AXIe Chassis is a modular instrument chassis that supports complex and high density testing. The chassis provides five slots for installing multiple AXIe based instrument modules such as the M8041A, M8051A, M8061A, and M8062A. Besides providing a frame for the installation of these instrument modules, the M9505A AXIe Chassis also provides power, a cooling system, a PCIe Gen2 local data bus, a Gigabit LAN interconnect, and a USB and PCIe connection for external host computer connectivity.

NOTE

The USB connection is recommended when using a laptop or desktop PC as an external controller. The PCIe connection is recommended for use with a desktop PC as an external controller only.

NOTE

PCIe connectivity between the M9505A AXIe Chassis and an external desktop PC controller is recommended when full channel plus large patterns need to be downloaded.

Refer to the *Keysight M9505A AXIe Chassis Startup Guide* to get detailed information about the AXIe chassis.



Figure 1 M9505A 5-slot chassis

M9505-00230 AXIe Embedded System Module (USB ESM)

The bottom slot of the AXIe chassis is reserved for the M9505-00230 Embedded System Module (ESM) which is factory installed. The ESM has a USB 2.0 interface as well as a PCIe x8, Gen1 and Gen2 compliant interface to connect an external host computer to the chassis.



Figure 2 M9505-00230 AXIe ESM

The ESM:

- runs the chassis embedded operating system (Windows 7) which manages all internal tasks and communications.
- tracks inserted modules and manages power requirements.
- monitors chassis temperature and controls variable- speed chassis fans.
- monitors module sensors and reports component failures to a system log.
- acts as a Gigabit Ethernet switch; forwards frames along the backplane.
- connects an external host computer to the chassis.
- synchronizes timing across all modules through the Keysight Trigger Bus, using an internal or external clock source.

LAN connector on AXIe ESM is not used. Only use LAN connection on the host computer.

Either the PCIe (desktop only) or USB (desktop or laptop) port can be used in this ESM but not both simultaneously. When you use the PCIe port, the USB port is automatically disabled until the PCIe port is no longer in use.

Keysight M9536A AXIe Embedded Controller Module

The M9536A AXIe Embedded Controller is a one slot module that you can install in the M9505A AXIe Chassis like any other instrument module. This module acts as a host computer when installed in the M9505A AXIe Chassis. It is always installed in slot 1 of the M9505A AXIe Chassis.

The following figure displays this module.



Figure 3 M9536A AXIe Embedded Controller Module

M8030A Modules

The M8030A supports the following modules.

- M8041A high-performance BERT generator-analyzer-clock 8/16 Gb/s
- M8051A high-performance BERT generator-analyzer 8/16 Gb/s
- M8192A Multi-channel synchronization module

The modules must be installed in the M9514A AXIe 14-slot chassis in the following way:

Table 3 M8030A Modules Arrangement

Slot Number	Module
# 1	M8030A-BU1 AXIe embedded controller. For M8030A-BU2 this slot is empty and covered with filler front-plane
# 2, 3 & 4	M8041A module
# 5 & 6	M8051A module
# 7	M9521A AXIe system module, always included in M8030A-BU1 or M8030A-BU2, must be in this slot
# 8 & 9	M8051A module
# 10 & 11	M8051A module
# 12 & 13	M8051A module
# 14	M8192A multi-channel synchronization module, always required in this slot

Details on the features and hardware components of each of the above mentioned modules are further described in this chapter.

M9514A AXIe Chassis

The Keysight M9514A AXIe 14-slot chassis (one slot for the AXIe System Module plus 13 instrument module slots) is a modular instrument chassis fully compatible with the AXIe 1.0 Hardware specifications. It allows multiple application-specific instrument modules to share a common chassis frame, power supply, cooling system, PCI Express (PCIe) Gen 2 data bus, Gigabit LAN hub, local bus for module-to-module signaling, and host PC connections.

Multiple chassis may be interconnected for scalability. The chassis provides 13 general purpose peripheral slots that accept 1U AXIe instrument modules. Each module slot has a Gen 2 x4 link (maximum of 2 GB/s data rate per module) to the chassis primary data 'fabric' hub—a x8 PCIe switch and data bus.

The chassis requires a full module height AXIe System Module (ASM) such as the Keysight M9521A, to manage chassis functions.

NOTE

The USB connection is recommended when using a laptop or desktop PC as an external controller. The PCIe connection is recommended for use with a desktop PC as an external controller only.

NOTE

PCIe connectivity between the M9514A AXIe Chassis and an external desktop PC controller is recommended when full channel plus large patterns need to be downloaded.

Refer to the *Keysight M9514A AXIe Chassis Startup Guide* to get detailed information about the AXIe chassis.



Figure 4 M9514A 14-slot chassis

M9521A AXle System Module (ASM)

The M9521A AXle System Module (ASM) is installed in the system slot of the M9514A (slot 7). It provides the system communication and synchronization functions required in an AXle chassis including:

- Trigger bus and clock routing.
- Managing clocks, including internal or external reference sources.
- Gigabit LAN switching with front panel RJ45 LAN connections.
- AXle Fabric 1 switching (Gen 2 x4 lanes to each module slot).



Figure 5 M9521A AXle System Module

Keysight M9536A AXIe Embedded Controller Module

The M9536A AXIe Embedded Controller is a one slot module that you can install in the M9505A AXIe Chassis like any other instrument module. This module acts as a host computer when installed in the M9505A AXIe Chassis. It may be installed in any slot in the of the M9505A AXIe chassis except for Slot 7 which is reserved for the ASM. However, to eliminate interference with the local bus used for E-Keying (if your AXIe modules use E-Keying), you should install the controller in one of the outside slots; e.g., either in slot 1 or slot 14.

The following figure displays this module.



Figure 6 M9536A AXIe Embedded Controller Module

The AXIe Embedded Controller:

- runs the chassis embedded operating system (Windows 7) which manages all internal tasks and communications.
- tracks inserted modules and manages power requirements.
- monitors chassis temperature and controls variable- speed chassis fans.
- monitors module sensors and reports component failures to a system log.
- acts as a Gigabit Ethernet switch; forwards frames along the backplane.
- connects an external host computer to the chassis.
- synchronizes timing across all modules through the Keysight Trigger Bus, using an internal or external clock source.

LAN connector on AXIe ESM is not used. Only use LAN connection on the host computer.

Either the PCIe (desktop only) or USB (desktop or laptop) port can be used in this AXIe Embedded Controller but not both simultaneously. When you use the PCIe port, the USB port is automatically disabled until the PCIe port is no longer in use.

NOTE

It is recommended to use the PCIe interface when more than 4 BERT channels are used in M8030A Multi-Channel BERT. By doing so, you can maintain enough communication speed between desktop and modules.

J-BERT M8041A High-Performance BERT Generator-Analyzer-Clock Module

The M8041A is an instrument module that can be installed into the M9505A 5-slot AXIe Chassis. This module occupies three slots.

The M8041A is a two channel bit error ratio tester with built-in clock and data generator for performing compliance and characterization measurements.

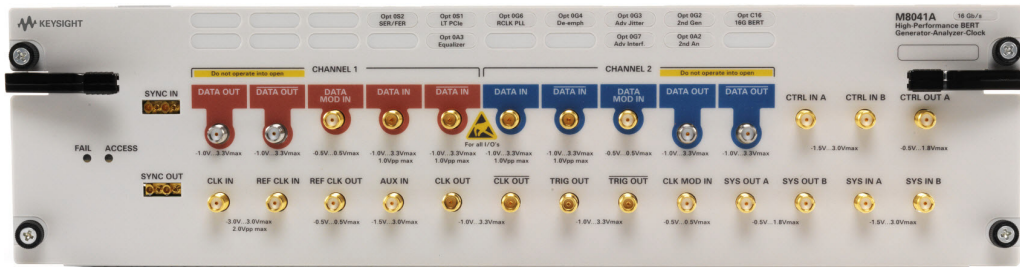

Figure 7 M8041A module

M8041A Features

- Two channel pattern generator (option 0G2) and two channel error detector (option 0A2)
- Data rate from 150 Mb/s to 16.2 Gb/s (option G16 or C16) for pattern generation and error detection
- Built in jitter injection (option 0G3)
- Adjustable ISI offered for M8041A and M8051A (option 0G5), software 2.0 and serial number \geq DE55300500
- Built in 8 tap de-emphasis (option 0G4)
- Built in receiver equalization (CTLE, option 0A3)
- Built in reference clock multiplier for pattern generator (option 0G6)
- Simultaneous common mode and differential mode level interference (option 0G7)
- Interactive link training (option 0S1, Software 1.5)
- Four universal control inputs with adjustable threshold
- Three universal control outputs with adjustable levels
- 2 Gb pattern memory per channel (requires software 1.5)

Refer to the *Online Help* installed and integrated into the M8070A software to learn about how to use this module.

M8041A Module Components

The following figure displays the front panel of the M8041A module with its various components labeled.

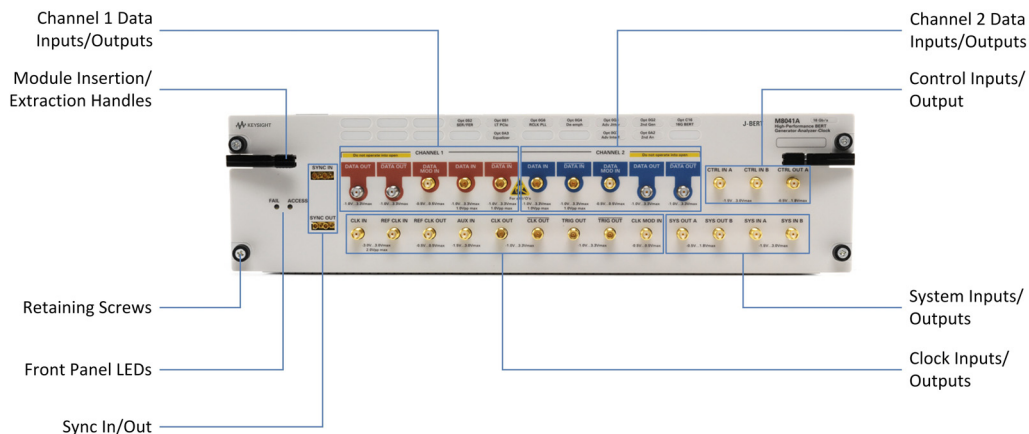

Figure 8 M8041A front panel view

As displayed in [Figure 8](#) on page -23, the M8041A module has the following components.

Table 4 Insertion/Extraction and Retaining

Component	Description
Retaining screws	The screws on both ends of the module are used to retain the module tightly inside the M9505A AXIe Chassis slot once you have fully placed it inside the chassis. To remove the module, you first need to loosen these screws ensuring that these screws disengage completely.
Module Insertion/Extraction Handles	The handles on both sides of the module to insert or eject the module from the slot of the M9505A AXIe Chassis.

Table 5 Front Panel LEDs

Connector Name	Active when...	Color
Fail	power-up fault condition	red
Access	power-up ready state	green
Data In x	input is overloaded	red
Data Out x	output is overloaded	red
Data Mod In x	input is active	green
Ctrl In A/Ctrl In B	logic level is detected	green
Ctrl Out A	output is active	green
Clk In	signal is detected	green
Ref Clk In	signal is detected	green
Ref Clk Out	output is active	green
Aux In	not used	n/a
Clk Out	output is active	green
Trig Out	output is active	green
Clk Mod In	input is active	green
Sys Out A/Sys Out B	output is active	green
Sys Ctrl In A/Sys Ctrl In B	logic level is detected	green

M8041A Front Panel Connector Inputs/Outputs

CAUTION

The inputs of the M8041A module are sensitive to static electricity. Therefore, take necessary anti-static precautions, such as wearing a grounded wrist strap, to minimize the possibility of electrostatic damage.

Table 6 Channel x Data Inputs/Outputs

Component	Description
Data Out and /Data Out	Differential data outputs (3.5 mm, female).
Data In and /Data In	Differential data inputs (3.5 mm, female).
Data Mod In	Accepts an external source for data out delay modulation (SMA, female).

Table 7 Clock Inputs/Outputs

Component	Description
Clk In	External clock input in the range of 8.1 to 16.2 GHz. This input is used as a direct clock for all channels in forwarded clock applications (SMA, female).
Ref Clk In	Reference clock input for applications that provide a host reference clock in the range of 10 MHz to 16 GHz. The clock signal may be SSC modulated and is used as the reference for the system clock of all Tx and Rx channels. A SSC tolerant PLL is used to multiply the reference clock to the system clock (SMA, female).
Ref Clk Out	The reference clock output is used to provide a 10 MHz or 100 MHz reference clock to the DUT or other test equipment (SMA, female).
Clk Out and /Clk Out	Differential clock output (3.5 mm, female).
Trig Out and /Trig Out	This output is used to send a trigger signal to another connected device, such as an oscilloscope (3.5 mm, female). It can also be used as a sub rate clock.
Clk Mod In	Input for delay modulation of the Trig Out and Clk Out channel. Both outputs are always affected (SMA, female).

Table 8 Sync In/Sync Out

Component	Description
Sync In	This input is used to synchronize two or more modules to a common system clock. It is connected to the Sync Out of the other module.
Sync Out	This output is used to synchronize two or more modules to a common system clock. It is connected to the Sync In of the other module.

Table 9 System Inputs/Outputs

Component	Description
Sys Out A/Sys Out B	System level control outputs used to signal events to the DUT or external instruments (SMA, female).
Sys In A/Sys In B	System level control inputs used to generate sequencer events (SMA, female).

Table 10 Control Inputs/Output

Component	Description
Ctrl In A/Ctrl In B	<p>The module has two control inputs at the front panel each with the following selectable functionality (SMA, female):</p> <p>Error Add Input Every rising edge at the input generates a single error in the output data stream by flipping a single bit. The maximum repetition rate is data rate divided by 4 times the vector size.</p> <p>Output Blanking If the input level is above the threshold level the pattern generator stops and only 0's are sent on data output. Normal operation resumes when the input level is below the threshold.</p> <p>Electrical Idle If the input level is above the threshold level the output amplifier enters electrical idle. Normal operation resumes when the input level is below the threshold.</p> <p>Gating Input If a logical high is applied to the gating input the error detector will ignore the incoming bits during a BER measurement. The ignored bit sequence is always a multiple of the vector size. For measuring data in bursts of bits, rather than a continuous stream of bits, a special operating mode is used. This mode is the burst sync mode. In this case, the signal at the gating input controls the synchronization and the error counting for each burst.</p>
Ctrl Out A	<p>The module has one control output at the front panel with the following functionality (SMA, female):</p> <p>Error Output This signal can be used to trigger an external instrument to help in error analysis. If an error occurs, a single RZ pulse is generated. Continuous errors will result in a clock signal.</p>

J-BERT M8051A High-Performance BERT Generator-Analyzer Module

The M8051A is an instrument module that can be installed into the M9505A 5-slot AXIe Chassis. This module occupies two slots and requires the M8041A module for proper operation.

NOTE

The three or four channel configuration requires a cable (provided with the M8051A) that connects the M8041A SYNC OUT to the M8051A SYNC IN to synchronize the two modules to a common system clock. Refer to the M8020A Installation Guide for instructions.

The M8051A is a two channel pattern generator and two channel error detector for performing compliance and characterization measurements.

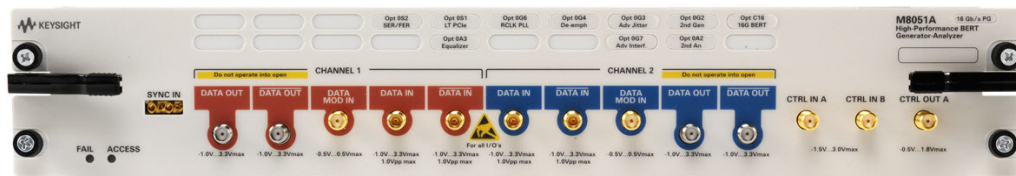

Figure 9 M8051A module

M8051A Features

The main M8051A features are the same as the M8041A features. Refer to [M8041A Features](#) on page 22.

M8051A Module Components

The following figure displays the front panel of the M8051A module with its various components labeled.

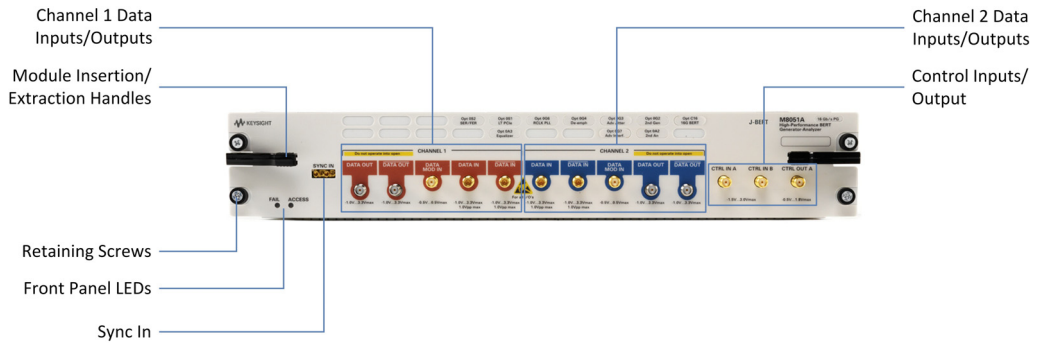

Figure 10 M8051A front panel view

As displayed in [Figure 10](#) on page -28, the M8051A module has the following components.

Table 11 Insertion/Extraction and Retaining

Component	Description
Retaining screws	The screws on both ends of the module are used to retain the module tightly inside the M9505A AXIe Chassis slot once you have fully placed it inside the chassis. To remove the module, you first need to loosen these screws ensuring that these screws disengage completely.
Module Insertion/Extraction Handles	The handles on both sides of the module to insert or eject the module from the slot of the M9505A AXIe Chassis.

Table 12 Front Panel LEDs

Connector Name	Active when...	Color
Fail	power-up fault condition	red
Access	power-up ready state	green
Data In x	input is overloaded	red

Connector Name	Active when...	Color
Data Out x	output is overloaded	red
Data Mod In x	input is active	green
Ctrl In A/Ctrl In B	logic level is detected	green

M8051A Front Panel Connector Inputs/Outputs

CAUTION

The inputs of the M8051A module are sensitive to static electricity. Therefore, take necessary anti-static precautions, such as wearing a grounded wrist strap, to minimize the possibility of electrostatic damage.

Table 13 Channel x Data Inputs/Outputs

Component	Description
Data Out and /Data Out	Differential data outputs (3.5 mm, female).
Data In and /Data In	Differential data inputs (3.5 mm, female).
Data Mod In	Accepts an external source for data out delay modulation (SMA, female).

Table 14 Sync In

Component	Description
Sync In	This input is used to synchronize two or more modules to a common system clock. It is connected to the Sync Out of the other module or to the clock distribution module if more than two modules are installed. The sync cable is required if M8051A is connected with M8041A module.

Table 15 Control Inputs/Output

Component	Description
Ctrl In A/Ctrl In B	<p>The module has two control inputs at the front panel each with the following selectable functionality (SMA, female):</p> <p>Error Add Input Every rising edge at the input generates a single error in the output data stream by flipping a single bit. The maximum repetition rate is data rate divided by 4 times the vector size.</p> <p>Output Blanking If the input level is above the threshold level the pattern generator stops and only 0's are sent on data output. Normal operation resumes when the input level is below the threshold.</p> <p>Electrical Idle If the input level is above the threshold level the output amplifier enters electrical idle. Normal operation resumes when the input level is below the threshold.</p> <p>Gating Input If a logical high is applied to the gating input the error detector will ignore the incoming bits during a BER measurement. The ignored bit sequence is always a multiple of the vector size. For measuring data in bursts of bits, rather than a continuous stream of bits, a special operating mode is used. This mode is the burst sync mode. In this case, the signal at the gating input controls the synchronization and the error counting for each burst.</p>
Ctrl Out A	<p>The module has one control output at the front panel with the following functionality (SMA, female):</p> <p>Error Output This signal can be used to trigger an external instrument to help in error analysis. If an error occurs, a single RZ pulse is generated with the width of half a vector length. Continuous errors will result in a clock signal.</p>

M8061A 32 Gb/s Multiplexer with De-emphasis Module

NOTE

Currently, the M8061A module is only supported by M8020A High-Performance BERT and not by M8030A Multi-Channel BERT.

The M8061A is an instrument module that can be installed into the M9502A 2- slot or M9505A 5- slot AXIe Chassis. This module occupies two slots.

The M8061A is used to characterize serial interfaces of up to 32 Gb/s. The M8061A provides four calibrated de-emphasis taps, which can be extended to eight taps, built-in superposition of level interference, and Clock/2 jitter injection.

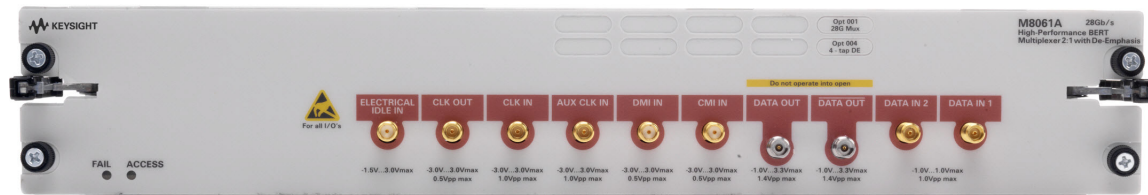

Figure 11 M8061A module

M8061A Features

- Expands data rate of M8041A and M8051A pattern generators up to 32 Gb/s enabling accurate and complete receiver stress testing
- Integrated and calibrated 4-tap de-emphasis, expandable to 8 taps
- Internal superposition of interference for common- mode and differential mode
- Transparent to jitter generated by the J-BERT M8020A, Clock/2 jitter can be added
- Electrical idle
- Control from M8020A user interface via USB

Refer to the *Online Help* installed and integrated into the M8070A software to learn about how to use this module.

NOTE

Phase-matched cables, such as the Keysight M8061A-804, must be used when connecting the M8041A data outputs to the M8061A data inputs (32 Gb/s configuration). In addition, use a bandpass filter from the M8041A CLK OUT to the M8061A AUX CLK IN, such as the M8061A-802 (11.4 to 15.6 GHz) or M8061A-803 (11.1 to 17.5 GHz).

NOTE

When using a bandpass filter from the M8041A CLK OUT to the M8061A AUX CLK IN, delay the M8041A DATA OUT 1 and DATA OUT 2 jitter by 600 ps.

M8061A Module Components

The following figure displays the front panel of the M8061A module with its various components labeled.



Figure 12 M8061A module components

As displayed in [Figure 12](#) on page -32, the M8061A module has the following components.

Table 16 Insertion/Extraction and Retaining

Component	Description
Retaining screws	The screws on both ends of the module are used to retain the module tightly inside the M9505A AXIe Chassis slot once you have fully placed it inside the chassis. To remove the module, you first need to loosen these screws ensuring that these screws disengage completely.
Module Insertion/Extraction Handles	The handles on both sides of the module to insert or eject the module from the slot of the M9505A AXIe Chassis.

Table 17 Front Panel LEDs

Connector Name	Active when...	Color
Fail	power-up fault condition	red
Access	power-up ready state	green

M8061A Front Panel Connector Inputs/Outputs

CAUTION

The inputs of the M8061A module are sensitive to static electricity. Therefore, take necessary anti-static precautions, such as wearing a grounded wrist strap, to minimize the possibility of electrostatic damage.

Table 18 Electrical Idle Input

Component	Description
Electrical Idle In	This input is used to enable/disable the output signal by an external control signal. If the input level is above the threshold level the module enters electrical idle. Normal operation resumes when the input level is below the threshold (SMA, female).

Table 19 Clock Inputs/Output

Component	Description
Clk Out	Clock output port is used to provide a clock signal to a device.
Clk In	Clock input port is used to receive a clock signal from the M8041A module.
Aux Clk In	Auxiliary clock input port is used to receive an auxiliary clock signal from the M8041A module.

Table 20 DMI/CMI Inputs

Component	Description
DMI In	Differential mode interference input independent of ground (SMA, female).
CMI In	Common mode interference input relative to ground (SMA, female).

Table 21 Data Inputs/Outputs

Component	Description
Data Out and /Data Out	Differential or single-ended data output (2.4 mm, female).
Data In 1 and Data In 2	Single-ended data input (3.5 mm, female).

M8062A 32Gb/s Front-end for J-BERT M8020A High-Performance BERT

NOTE

Currently, the M8062A module is only supported by M8020A High-Performance BERT and not by M8030A Multi-Channel BERT.

The M8062A extends the data rate of the J-BERT M8020A Bit Error Ratio Tester to the speeds required for testing devices with lane rates in the 25-28 Gb/s range. When combined with a two channel M8041A, the system provides data pattern generation and full-rate error analysis for users developing 100G class serial data link components and systems with lane rates up to 32.4 Gb/s.

Typical Applications:

- 100G Serdes development (CAUI-4)
- Optical Transceiver development for 100G-SR4, LR4, and ER4, 32G Fibre Channel
- Thunderbolt 20G
- Active Optical Cables



Figure 13 M8062A module

M8062A Features

- Extends maximum data rate of J-BERT M8020A up to 32.4 Gb/s
- Seamless control of pattern generator and error analyzer
- Integrated 8-tap de-emphasis
- Built in ISI generator for channel emulation
- Analyzer equalization eliminates errors resulting from closed eyes in loop back path

Refer to the *Online Help* installed and integrated into the M8070A software to learn about how to use this module.

NOTE

Phase-matched cables must be used when connecting the M8041A data and clock outputs to the M8062A data and clock inputs. The provided cable set, Keysight M8062-61643, meets this requirement.

M8062A Module Components

The following figure displays the front panel of the M8062A module with its various components labeled.



Figure 14 M8062A module components

As displayed in **Figure 14** on page -36, the M8062A module has the following components.

CAUTION

The inputs and outputs of the M8062A module are sensitive to static electricity. Therefore, take necessary anti-static precautions, such as wearing a grounded wrist strap, to minimize the possibility of electrostatic damage.

Table 22 Insertion/Extraction and Retaining

Component	Description
Retaining screws	The screws on both ends of the module are used to retain the module tightly inside the M9505A AXIe Chassis slot once you have fully placed it inside the chassis. To remove the module, you first need to loosen these screws ensuring that these screws disengage completely.
Module Insertion/Extraction Handles	The handles on both sides of the module to insert or eject the module from the slot of the M9505A AXIe Chassis.

Table 23 Front Panel LEDs

Connector Name	Active when...	Color
Fail	power-up fault condition	red
Access	power-up ready state	green

Table 24 Sync In/Clean Clk Out

Connector Name	Description
Sync In	This input is used to synchronize two or more modules to a common system clock. It is connected to the Sync Out of the other module. The sync cable is required if M8062A is connected with M8041A module.
Clean Clk Out	Half-rate, or divided, clock output with no applied jitter.

M8062A Front Panel Pattern Generator Connectors

Table 25 Electrical Idle Input

Component	Description
Electrical Idle In	This input is used to enable/disable the output signal by an external control signal. If the input level is above the threshold level the module enters electrical idle. Normal operation resumes when the input level is below the threshold (SMA, female).

Table 26 Pattern Generator Clock Inputs/Output

Component	Description
Clk Out	Half-rate Pattern Generator clock output. Carries the same jitter as the full-rate data output.
Clk In	Pattern Generator clock input (half-rate). Connect to clock output of M8041A.
Aux Clk In	Alternate Pattern Generator clock input (half-rate). Typically unused.

Table 27 DMI/CMI Inputs

Component	Description
DMI In	Differential Mode Interference input. Applies a single-ended, external interference source differentially to the data output (SMA, female).
CMI In	Common Mode Interference input. Applies a single-ended, external interference source to both the normal and complement data output signals (SMA, female).

Table 28 Pattern Generator Data Inputs/Outputs

Component	Description
Data Out and /Data Out	Differential or single-ended, full-rate data output to the device under test. Unused outputs must be terminated in 50-ohms. (2.4 mm, female).
Data In 1 and Data In 2	Single-ended, half-rate data inputs from the M8041A module (3.5 mm, female).

M8062A Front Panel Analyzer Connectors

Table 29 Error Analyzer Data Inputs/Outputs

Component	Description
Data In and /Data In	Differential or single-ended, full-rate data input from the device under test. Unused input should be terminated in 50-ohms. (2.4 mm, female).
Data Out 1 and Data Out 2	Single-ended, half-rate data outputs to the M8041A module (3.5 mm, female).

Table 30 Error Analyzer Clock Inputs/Output

Component	Description
Clk Out	Half-rate Error Analyzer clock output, synchronous with analyzer sampling.
Clk In	Half-rate, Error Analyzer clock input. Allows external clocking of the Error Analyzer.

M8192A Multi-Channel Synchronization Module

The M8030A multi-channel BERT uses the M8192A synchronization module to synchronize the M8030A modules that are installed in the AXIe chassis. The clock connections are routed through special cables that are connected on the front panel between the M8192A module and the M8030A modules.



Figure 15 M8192A synchronization module

When running in synchronous mode, all of the M8030A modules work with the same sample clock and start at the same time. One of the M8030A modules (M8041A) is designated as the “master” module. The common sample clock is derived either from the master module’s internal clock synthesizer or from an external sample clock that is connected to the master module’s sample clock input.

For further information, please check the Keysight website www.keysight.com/find/m8192a for the latest version of related documents and data sheet.

Host Computer

A host computer is used to:

- host all the software components of the instrument modules needed to control, configure, and use the modules.
- communicate with the ESM of the M9505A AXIe Chassis to allow you to monitor and control the chassis.

A host computer can be:

- the M9536A AXIe Embedded Controller module.
- a laptop with a USB port.
- a desktop PC with a USB port or x8 or wider PCIe slot for the cabled PCIe adapter card.

Refer to the [Computer Hardware and Software Requirements](#) on page 44 for external host computer minimum requirements.

2 Basic Setup for M8020A

Step 1 - Unpack the Shipment / 42

Step 2 - Set up the M8020A / 43

Step 3 - Set up the External Host Computer (not required for
M8020A-BU1) / 43

Step 4 - Connect the M9505A AXIe Chassis to a Power Supply / 46

Step 5 - Power Up (if connecting via PCIe) / 47

Step 6 - Verify Basic M8020A Operation / 48

Step 7 - Install Keysight IO Libraries Suite (not required for M8020A-BU1)
/ 49

Step 8 - Install M8070A Software (not required for M8020A-BU1) / 49

Step 9 - Install the Licenses / 50

Step 10 - Turning off the Chassis and Modules / 61

Step 11 - Connecting the M8020A to the Device Under Test (DUT) / 61

Step 1 - Unpack the Shipment

The M8020A-BU1 or M8020A-BU2 is shipped with the modules pre-installed in the M9505A AXIe Chassis.

Unpack and verify the shipment contents to check if you have received all the items that you ordered. The shipment contents can vary depending on the options that you ordered. Therefore, the shipping list delivered with the shipment should supersede these lists.

Table 31 Typical contents of an M8020A instrument shipment

Item	Description
M8020A-BU1 or M8020A-BU2	The M8020A that you ordered. All modules are pre-installed in the M9505A AXIe Chassis.
Accessories	The accessories will vary depending on the M8020A and the options that you ordered while purchasing the module. Accessories include standard items that are shipped with the M8020A as well as optional items that you ordered separately. (Please check the M8020A and M8061A/M8062A product data sheet for the latest list of default and optional accessories. Latest version can be downloaded from www.keysight.com/find/m8020a)
M8070A	CD-ROM with M8070A system software.
Start Here	Document which provides instructions to be followed before operating the J-BERT M8020A High-Performance BERT.
Tips for Preventing Damage to J-BERT M8020A High-Performance BERT	Document which provides tips for preventing damage to J-BERT M8020A High-Performance BERT.
Getting Started Guide	This document, <i>J-BERT High-performance BERT Getting Started Guide</i> . (Please check the Keysight website: www.keysight.com/find/m8020a for the latest guide.)

Carefully inspect all items in the shipment for any damage.

Return the Damaged/Defective Item to Keysight for Repair/Replacement

If anything is missing, defective, or damaged,

- 1 Review the warranty information shipped with your product or check the warranty information on Keysight website.
 - To check the warranty information on your module, go to www.keysight.com/find/warranty and specify the module's model number (for example, M8041A) in the Product Number field, and specify the serial number from the top of the module in the Serial Number field.
- 2 Contact the nearest Keysight Sales Office. If you need assistance finding Keysight contact information, go to www.keysight.com/find/assist (worldwide contact information for repair and service).

Step 2 - Set up the M8020A

This step does not have to be performed while verifying the basic setup for power up and connectivity. However, you will need to decide on a benchtop or rack mounted usage of the M8020A after this basic verification. For the procedures on how to set up the M8020A, refer to the *M8020A Installation Guide*.

Step 3 - Set up the External Host Computer (not required for M8020A-BU1)

NOTE

Perform this step if you are using a laptop or desktop computer as the host computer.

The host computer communicates with the ESM and instrument modules in the chassis and hosts all the software components needed to use the instrument modules.

Computer Hardware and Software Requirements

The following are the hardware and software requirements that should be met on the host computer before the installation of software components on this computer:

Hardware requirements

- Pentium® processor 1 GHz or equivalent
- 16 GB available RAM
- USB 3.0 connection
- PCIe 2.0/8x (only for highest data throughput and desktop PC)
- VGA resolution 1024 x 768
- 1.5 GB or more free hard disc space

Software requirements

- The following operating systems are supported:
 - Windows 7 (64 bit) SP1
 - Windows 8 (64 bit)
 - Windows 8.1 (64 bit)
- Keysight I/O libraries version 16.3

NOTE

The M8070A software is required to control the M8020A. M8070A-OTP or M8070A-ONP license is required for controlling hardware.

NOTE

PCIe connectivity between the M9505A AXIe Chassis and an external desktop PC controller is recommended when full channel plus large patterns need to be downloaded.

To connect via USB

If you are planning to use USB connectivity between the M9505A AXIe Chassis and host computer, then you can use a laptop or desktop computer with USB 3.0 support as the host computer.



USB Port

Figure 16 USB port on the front panel of the AXIe ESM

To connect via PCIe

In case of PCIe connectivity, the host computer can be a desktop PC with an available x8 or wider PCIe slot.

Review the Keysight recommended list of host computers at <http://literature.cdn.keysight.com/litweb/pdf/5990-7632EN.pdf> that are compatible with the Keysight M9505A AXIe Chassis.



PCIe Port

Figure 17 PCIe port on the front panel of the AXIe ESM

Step 4 - Connect the M9505A AXIe Chassis to a Power Supply

You can use an external power supply, typically AC power mains.

- 1 The instrument module uses the power supplied by the M9505A AXIe Chassis in which it is installed. The M9505A AXIe Chassis power cord comes with the chassis shipment. Insert the power cord into the inlet at the rear of the chassis.
- 2 Connect the cord to an appropriate AC power main.
- 3 Push the circuit breaker to the right, which is the ON position.

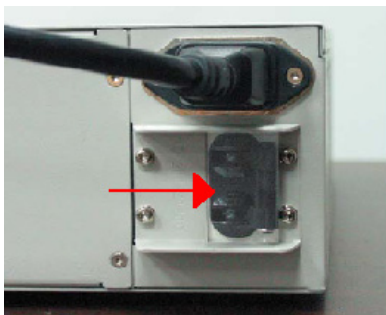

Figure 18 Chassis circuit breaker

Step 5 – Power Up (if connecting via PCIe)

Power up all the connected hardware components in the M9505A AXIe Chassis.

- 1 Press the ON/Standby button on the front panel of the chassis to power on the chassis.



Figure 19 Chassis ON/standby button

- 2 After powering up the chassis, wait until the Status LED of the ESM is solid green. This ensures that the PCIe channel in the chassis is ready for the successful connectivity of the chassis to the host computer.
- 3 Wait until the Access LED(s) of the module(s) in the chassis is/are solid green.
- 4 Power up the host computer. By this time, the Status LED of the ESM in the chassis and the Access LED(s) of the module(s) should have been steady green indicating a power ready status of the setup.

The step to power up the host computer is not required if you are using the M9536A AXIe Embedded Controller module as the host computer because it gets powered on simultaneously with the chassis through the chassis backplane.

NOTE

If you plan to connect the J-BERT M8020A to a corporate LAN and the M9536A AXIe Embedded Controller is installed, you must use the Ethernet port available on the M9536A AXIe Embedded Controller or the LAN port on the external PC.

NOTE

To power down a chassis, first turn off the host computer and then power down the chassis using the On/Standby button on its front panel.

If you are using the M9536A AXIe Embedded Controller module as the host computer, ensure that you first shut down the controller by executing the Windows shutdown process.

Do not use the circuit breaker for routine chassis turn off.

The module(s) are turned off automatically with the chassis.

Step 6 - Verify Basic M8020A Operation

After powering ON the connected hardware components, you can verify if you have correctly set up the hardware if:

- a steady green status light is displayed on the ESM of the M9505A AXIe Chassis indicating that the chassis has powered up successfully.
- the Access LED on the front panel of the instrument module turns on indicating that the module is in a power- ready state.
- the Out of Service (OOS) LED on the front panel of the M9536A AXIe Embedded Controller turns off. (Applicable only when you are using M9536A AXIe Embedded Controller as the host computer).

If the chassis does not power up to a steady green Status light, or powers up to a steady red light, the chassis has detected a failure and requires service.

If the Fail LED on the front panel of the instrument module is steady red and does not turn off, it indicates a power fault condition. In such a situation, the instrument module may require repair/service.

Contact your Keysight representative to replace or service the chassis/module.

Step 7 - Install Keysight IO Libraries Suite (not required for M8020A-BU1)

IO Libraries Suite version 16.3 or later is required. Always use the latest version of the Keysight IO Libraries.

NOTE

Perform this step if you are setting up an M8020A-BU2 system or the host computer you are using as part of the M8020A system requires I/O library installation.

- 1 Disconnect any devices connected to the host computer.
- 2 If open, close all applications on the host computer.
- 3 Insert the *Automation-Ready* CD in your CD-ROM drive or download and install the IO Libraries from www.keysight.com/find/iosuite.
- 4 Follow the instructions as prompted during the installation.
- 5 After installation, you will see the Keysight IO icon in the taskbar notification area of the host computer screen.

Step 8 - Install M8070A Software (not required for M8020A-BU1)

NOTE

Perform this step if you are setting up an M8020A-BU2 system or the host computer you are using as part of the M8020A system requires I/O library installation.

You will need to install the M8070A Software and license file to control the M8020A.

NOTE

A CD-ROM is shipped when ordering the M8070A (part of the M8020A configuration).

To install the software

- 1 Insert the CD ROM into the host computer or download the latest M8070A software from www.keysight.com/find/m8020a.
- 2 Double-click the setup (.exe) file.
The InstallShield Wizard is displayed.
- 3 If displayed, click **Install** to continue or click **Next** if the system controller meets the minimum system configuration requirements displayed by the wizard.
- 4 When displayed, accept the license agreement and click **Next**.
- 5 Click **Install** to start the installation then follow any on-screen prompts/instructions.
- 6 In Windows click **Start > All Programs > M8070A Keysight > M8070A Keysight** to verify software installation. The Startup screen of the M8070A software should display.

Step 9 - Install the Licenses

NOTE

Please note that the license installation procedure is same for M8020A and M8030A system. Therefore, if you want to install licenses for M8030A system, please refer to instructions provided in this section.

NOTE

All M8020A-BU1 licenses have been pre-installed (except for a floating/networked license). All other system configurations require license installation as described in this step.

The M8070A software requires a license to communicate with the M8020A hardware. You either purchased an M8070A license to install on a dedicated host computer (M8070A- OTP) or one that can be installed on a network server that will be used as a license server for operation over a company network (M8070A-ONP, floating/networked).

In addition to the M8070A license, the M8020A, being a modular product, includes different sets of modules hosted in an M9505A AXI chassis. Each module has its own licenses corresponding to specific features. Module licenses are pre-installed at the factory according to the specific options that were ordered.

For more detailed information about licensing, refer to the *M8070A User Guide*.

Installing M8070A-OTP License (not required for M8020A-BU1)

The following procedure shows how to redeem and install an M8070A license on a dedicated host computer.

- 1 Locate the **Software License Entitlement Certificate**.
- 2 Follow the instructions on the **Software License Entitlement Certificate** to redeem your license.
- 3 You will receive a license file (in an email). The file has the suffix .lic.
- 4 Follow the instructions in the email to complete the installation of the license file.
- 5 In the M8070A software interface, verify that the license has been installed by selecting **Utilities > Licenses...** then viewing the license status in the **Installed** column.

Installing M8070A-ONP Floating/Networked License

An M8070A-ONP floating/networked license resides on a network server and is accessible by multiple users. The user checks out a license each time the software is accessed. The server tracks the number of licenses checked out and the number of licenses available for use.

The server must be running license services. This server can be a dedicated computer running the license server or it can run license services and the M8070A software concurrently.

Firewall Configuration for Licensing

If your instrument or PC has a firewall installed and enabled, your system administrator may need to allow certain executables and/or a limited range of port numbers to go through the firewall. This topic discusses those ports and configuration for three common firewalls.

NOTE

Typically, the Licensing installer will do the necessary configuration of the Windows firewall. These instructions are provided in case you need to verify or modify the firewall configuration manually.

- 1 In Windows click **Start > Control Panel > System and Security > Windows Firewall**.
- 2 In the left pane, click **Allow a program or feature through Windows Firewall**. If this is not accessible, perform the following alternate procedure:
 - a In Windows, click the **Start** button and enter **Allow a program through Windows Firewall** in the search field.
 - b In the Control Panel, select **Allow a program through Windows Firewall** as shown in **Figure 20** on page -52.

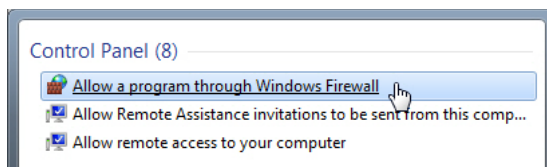

Figure 20 Control Panel

- 3 Click **Change Settings**. You may need to provide an administrator password or provide confirmation for this action.
- 4 Click on the **Allow another program** button.

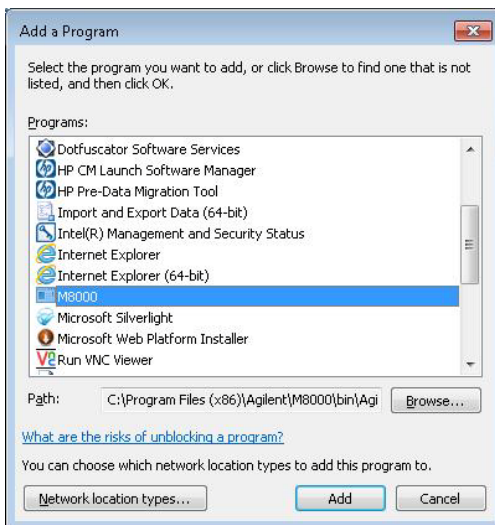

Figure 21 Select program

- 5 Select **M8000** then click **Add**.
- 6 Add program path:
C:\Program Files (x86)\FlexNet Publisher License Server Manager\ladmin.exe.
- 7 Repeat step 4 and step 5 to add the other programs.
- 8 In the **Allowed Programs** dialog, click **OK** to save the settings.

Installing the FlexNet License Manager

The **FlexNet License Manager** tools associated with floating licenses are available from Flexera at www.keysight.com/find/fnptools. You must use version 11.11.1 or higher.

FlexNet provides two different license server executables: *lmgrd.exe* and *ladmin.exe*. You can use either one or the other.

ladmin Installation

The following procedure describes how to install *ladmin.exe* (server side):

- 1 Copy the *agilent.lic* file from the Keysight Licensing installation path (typically found in, *C:\Program Files\Agilent\ACCL\Licensing\bin* or *C:\Program Files (x86)\Agilent\ACCL\Licensing\bin*) into the licensing folder. (The license filename will change to *agilent0.00.lic* after successful installation.)
- 2 Determine whether the target system has Java installed, if not, install it from www.java.com. The Java virtual machine is required to run the *ladmin.exe* installer.
- 3 Run the *ladmin.exe*. (Right-click the installer file and **Run as Administrator**.) During the installation:
 - 1 Accept the default installation path.
 - 2 Check the box to **Install Visual C++ 2005 SP1 Redistributable**.
 - 3 On the **Service Configuration** page, enter the **HTTP Port Number**: '8090'.
 - 4 On the **Service Configuration** page, select the check-box to **Run as Service**.
 - 5 On the **Start the Server** page, select the check box to **Start server now**. If you don't do it now, then you will need to start the *ladmin* service before configuring the license server.

- 4 If the web browser does not show the license configuration page, just exit the browser and reboot the PC.
- 5 After reboot start the browser and use the following <http://localhost:8090/> address again. Now you should see the web configuration page of the *ladmin*.
- 6 However, if you see the message 'The page can't be displayed ...' again the firewall of windows has blocked the access. You may need to allow certain executables and/or the port number to go through the firewall. For firewall settings, refer to [Firewall Configuration for Licensing](#) on page 51.
- 7 In the login page, if you have not previously set up a login, sign in as "user admin" with password "admin". You will then be required to change the password.
- 8 Start the browser and use the following <http://localhost:8090/> address again.
- 9 The *ladmin* is installed as a service. To check the state of the service, right-click on the **Computer** icon on the desktop and then select **Manage**. Click on **Services** and check if the service *ladmin* is started.
- 10 Login to the *ladmin* web configuration page. Add the *agilent.lic* and the *M8070A-ONP*.
`C:\Program Files (x86)\Agilent\ACCL\Licensing\bin\agilent.lic`
`...\1001562893_1166729.lic`
- 11 On the client side, install the M8070A software on the client PC.
- 12 Install the edited license M8070A-ONP on the client (import license in the Keysight License Manager).
- 13 In the **Keysight License Manager**, verify by opening the 'Licenses list' and 'Feature Detail' view. The following illustration displays the 'Licenses list' view.
- 14 Start the M8070A software. From the menu bar, select **Utilities > Licenses...** The M8070A license dialog will display the installed licenses.
- 15 Request a floating license. For details, refer to [Acquiring Floating Licenses](#) on page 55.

Lmgrd Installation

The following procedure describes how to install *lmgrd.exe* (server side).

- 1 Copy the *agilent.lic* file from the license installation path (typically found in, *C:\Program Files\Agilent\ACCL\Licensing\bin* or in *C:\Program Files (x86)\Agilent\ACCL\Licensing\bin* into the licensing folder. (The license file name will change to *agilent0.00.lic* after successful installation).
- 2 Copy the appropriate version of *lmgrd.exe* (32-bit or 64-bit, depending on your operating system) to the target system. It is recommended to put *lmgrd.exe* in the Keysight Licensing installation path (see step 1 for path information).
- 3 Install floating licenses to the licensing folder, *C:\Program Files\Agilent\Licensing*.
- 4 Open a DOS prompt and change directory to the location of *lmgrd.exe*.
- 5 Launch *lmgrd.exe* with the following command:
`lmgrd.exe -z -c "C:\Program Files\Agilent\licensing"`
- 6 If the license server is running (*lmgrd.exe*) you will see the licenses in the Keysight License Manager on the server.
- 7 On the client side, install the edited license M8070A-ONP (import license in the **Keysight License Manager**)
- 8 In the **Keysight License Manager**, verify by opening the 'Licenses list' and 'Feature Detail' view.
- 9 Start the M8070A software. From the menu bar, select **Utilities > Licenses...** The M8070A license dialog will display the installed licenses.
- 10 Request a floating license. For details, refer to [Acquiring Floating Licenses](#) on page 55.

Acquiring Floating Licenses

- 1 Contact your Keysight Technologies representative to purchase licenses for your software. You will receive an order number and certificate number, which you will use to request a license file in step 3.
- 2 Select and configure your license server machine as described above. For more information, refer to the *Flexera Software License Administration Guide*. You must install Keysight Licensing on the license server computer, as described in [Creating a New License Service Using *lmadmin.exe*](#) on page 57, before requesting a license file in step 3.

- 3 Request a license file for your license server machine:
 - 1 Determine the host name and serial number (10-digit alphanumeric sequence, which is the second component of the host ID) of your license server from **Keysight License Notifier's About** box.
 - 2 To display the **About** box, right-click the **Keysight License Notifier** icon in the notification area (bottom right of your screen) and click **About Keysight License Notifier**.
 - You will need the highlighted items shown in the following figure:



- Visit the **Keysight Software Manager** website to request a license file.
- 4 When you receive your license via e-mail from Keysight Technologies, carefully read the instructions sent with the license. If the license is a "served" or "floating" license, put it in the directory *C:\Program Files\Agilent\licensing* on the license server.

Creating a New License Service Using lmadm.exe

- 1 To access the lmadm **license server management** interface, open a Web browser and navigate to `http://<server>:8080`, where <server> is the name of the computer on which the **license server** is running. For this first-time configuration, you need to be logged on to the license server computer, so you can just navigate to `http://localhost:8080`.

NOTE

If the browser cannot find the web page, then the lmadm service may not be running on the server. Go to Start > Control Panel > Administrative Tools > Services, find “lmadm” and Start the service. After starting the service, refresh or try navigating the browser to the Web page again.

- 2 Select the **Administration** tab.
- 3 Log in. If you have not previously set up a login, sign in as user "admin" with password "admin". You will then be required to change the password (don't forget this password).
- 4 Select the **Vendor Daemon Configuration** tab.
- 5 Select **Import License**.
- 6 Browse to the new floating license file. You can only choose one file at this step, so if you have more than one **license** file, then pick one of them and click **Import License**.

NOTE

To add more license files, perform the following steps.

- 7 An **Import Error** and an **Import Warning** will be displayed indicating that it can't find the *Agilent.exe* file. Click **OK**.
- 8 Select the “Keysight” vendor daemon and click **Administer**.
- 9 Change the **License File or Directory** to “licenses\Agilent” instead of the file you specified above. This will enable you to easily add more **license** files.
- 10 Change the **Vendor Daemon Location** (which is blank) to the location of the *Agilent.exe* file:
 - a For 32- bit Windows, enter “C:\Program Files\Agilent\ACCL\Licensing\bin\Agilent.exe”.
 - b For 64- bit Windows, enter “C:\PROGRA~2\Agilent\ACCL\Licensing\bin\Agilent.exe”.

NOTE

For 64-bit Windows, the file is in “C:\Program Files (x86)”, but the Web page does not allow you to enter a file path containing an open or close parenthesis, so you must instead enter the short file name “C:\PROGRA~2” of the path.

- 11 Click **Save**.
- 12 Start the daemon by pressing **Start**.
- 13 To verify the status of the **server**, select the **Dashboard** tab and click the **Concurrent** button. Wait for the Web page to refresh. If the “Keysight” daemon is not selected in the vendor drop- down list in the upper right side of the **Licenses** page, then select it. Click **Select**. You will now see the list of floating **licenses** that are managed by *ladmin.exe*.

Installing and Setting up Client PC Floating Licenses

The following procedures show how to install and set up client PC floating licenses. Repeat this procedure for each client PC.

- 1 Ensure that you have the Keysight Licensing Services and the M8000 software to be installed on the client PC.
- 2 Create the Client floating license files.
The Client floating license files redirect licensing requests to the license server. Only one client floating license file needs to be created. This client floating license file is copied and re- used by each client PC.
 - a Make a copy of the original license server floating license file. Remove all line entries except these three lines, which you must modified as shown.
 - “SERVER” line: Keep original text
 - “VENDOR” line: If the optional VENDOR line “port” number is included in the original server license file, remove the optional “Vendor” daemon TCP/IP port number from the line
 - “USE_SERVER” line: Keep original text
- 3 Install the client floating license files.
 - a Start the Keysight License Manager by double clicking the **Keysight License Notifier** icon or click **Start > All Programs > Keysight License Manager > Keysight License Manager**.
 - b To install the license file, drag-and-drop the license file onto the Keysight License Manager “**License Features**” window.

Alternatively, you can click the **Keysight License Manager** menu File.

- c Install and follow the prompts to install the license file. The license files are stored in different folder locations depending on whether the license Server and client reside on separate PCs or the same PC.
 - License Server and Client reside on separate PCs: *C:\Program Files\Agilent\licensing*
 - License Server and Client reside on same PC: *C:\Program Files\Agilent\licensing\Remote Licenses*
- 4 Verify the client PC configuration is correct.

When the license file is successful installed, The client floating licenses that are available on the license server are listed in the Keysight License Manager “**License Products and Features**” window. To view the available licenses, select the **Localhost** tree, **Remote Licenses** node. Ensure that your licensed options and features are shown.

Installing Module Licenses (for upgrades only)

Installing module licenses is only necessary if you add module options onsite. Module licenses enable specific options in the modules of the M8020A system. Once a module license has been installed using the Keysight License Manager, the next time the M8070A software and M8020A hardware are started, the license is recognized by the M8070A software and compared to the module’s serial number. If the PC Host ID and serial number match, the EEPROM in the module is programmed and the option is enabled. Even if the M8070A software license is transported to another host computer, the module option will remain enabled.

The following procedure shows how to redeem and install a module license.

- 1 Locate the Software License Entitlement Certificate (email or paper copy).
- 2 Follow the instructions on the Software License Entitlement Certificate to redeem your license.
- 3 You will receive a license file (in an email). The file has the suffix .lic.
- 4 Follow the instructions in the email to complete the installation of the license file.
- 5 In the M8070A software interface, verify that the license has been installed by selecting **Utilities > Licenses** then viewing the license status in the **Installed** column.

Transporting an M8070A License

Transportable licenses are licenses that can be moved from one host controller to another using the Keysight License Manager. For detailed information about transportable licenses, refer to the *M8070A User Guide*.

If you need to download and install the Keysight License Manager, go to the following Web page: <http://www.keysight.com/find/LicenseManager>

- 1 Start the **Keysight License Manager** by double clicking the **Keysight License Notifier** icon or click **Start > All Programs > Keysight License Manager > Keysight License Manager**.
- 2 In the **Keysight License Manager**, click on **Help > Keysight License Manager Help** and perform the procedure in the **Transporting Licenses** help topic.

Affix Option Label (optional)

Whenever the M8020A is upgraded with additional options, it is recommended that you affix the corresponding label(s) to the front panel of the module. The option labels provide a quick view of which options are installed in each module. [Figure 22](#) on page -60 shows the option label sheet provided with your M8020A system.

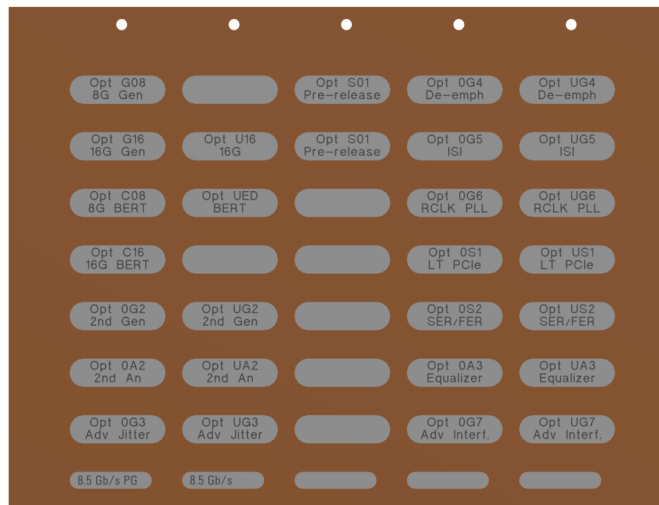

Figure 22 Option label sheet

- 1 Locate the option label sheet shown in Figure 22 on page -60.
- 2 Affix the option labels as shown in Figure 23 on page -61.

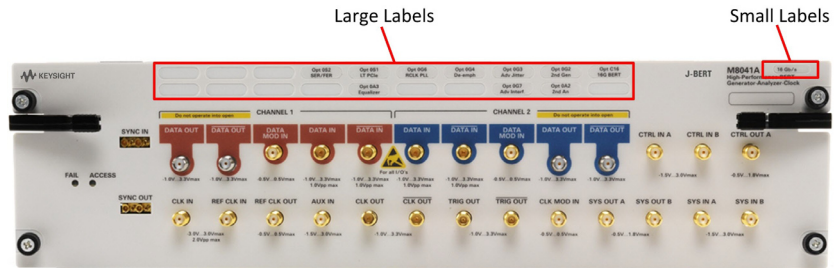

Figure 23 Affix option labels

Step 10 - Turning off the Chassis and Modules

Turn off the chassis and module in the following sequence:

- 1 Turn off the host computer. If you are using the Keysight AXIe Embedded Controller module as the host computer, ensure that you shut down the controller by executing the Windows shutdown process.
- 2 Turn off the chassis by pressing the chassis ON/STANDBY switch on the front panel of chassis. Do not use the circuit breaker for routine turn off. The module(s) are turned off automatically with the chassis.

Step 11 - Connecting the M8020A to the Device Under Test (DUT)

This section describes how you can connect the M8020A to a DUT.

NOTE

The 32G, or three or four channel 16G configurations require a cable (provided with the M8051A or M8062A) that connects the M8041A SYNC OUT to the M8051A/62A SYNC IN. Refer to the M8020A Installation Guide for instructions.

NOTE

If you are connecting M8020A over USB, make sure to disable the “Sleep Mode” of the external PC or laptop. Failing to do so may cause you to re-initialize the M8070A software.

Typical Test Setup Example

Figure 24 on page -62 is an example of a common test setup for testing a DUT.

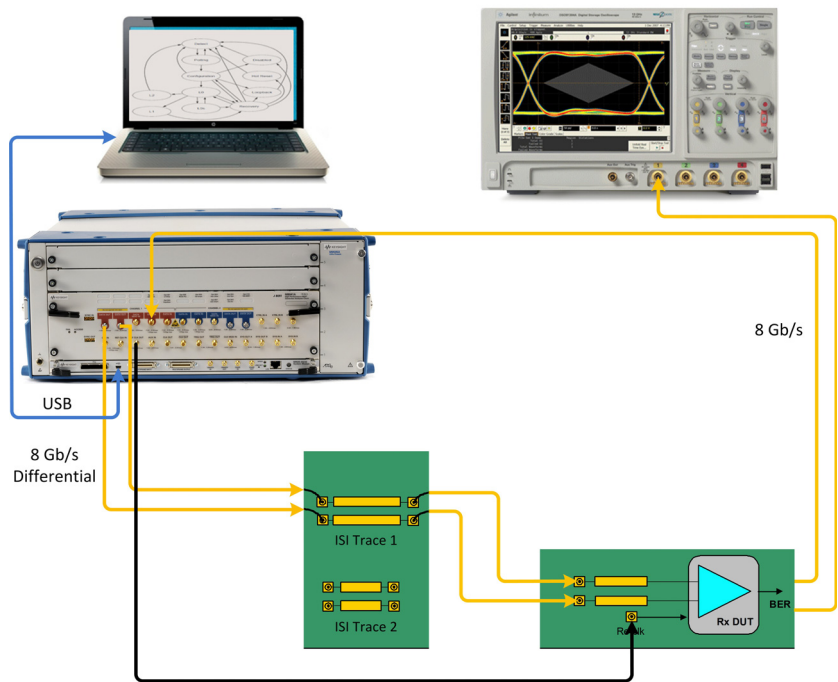

Figure 24 Typical test setup example

M9536A Embedded Controller Setup Example

Figure 25 on page -63 shows a basic setup using the M9536A Embedded Controller. The embedded controller module must be installed in slot 1 of the M9505A AXIe Chassis. The embedded controller module communicates with the ESM through the chassis backplane. Therefore, there is no need to establish any external PCIe/USB or LAN connection between the embedded controller module and chassis.

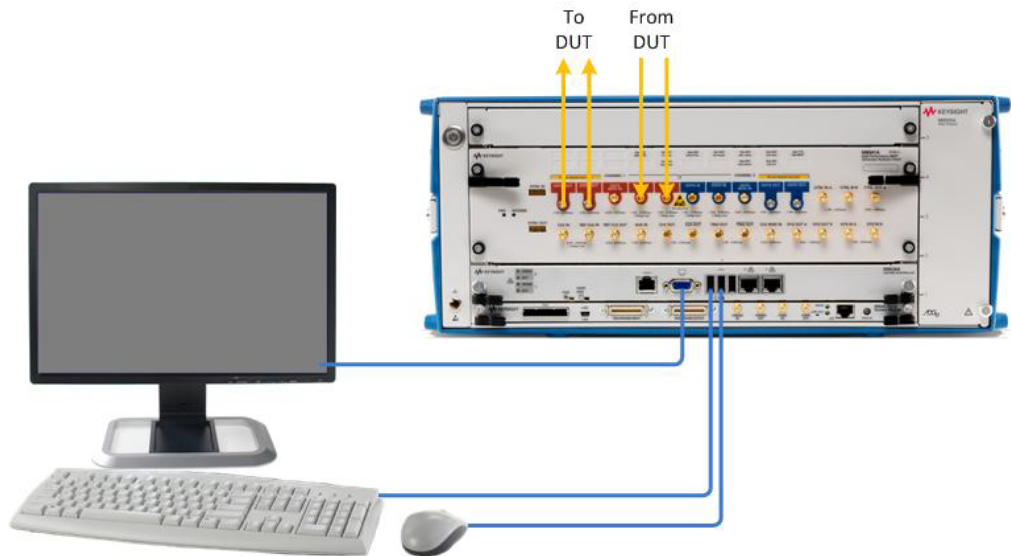

Figure 25 M9536A embedded controller setup example

M8061A Multiplexer Setup Example (32 Gb/s)

Figure 26 on page -64 shows a basic setup using the M8061A multiplexer with the M8041A module in **Mux** mode.

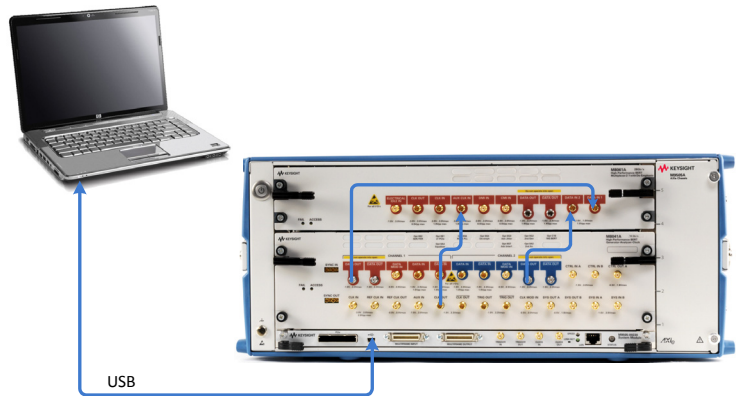

Figure 26 M8061A with M8041A (Mux mode) setup example

Figure 27 on page -64 shows a basic setup using the M8061A multiplexer with the M8041A module in **Demux** mode.

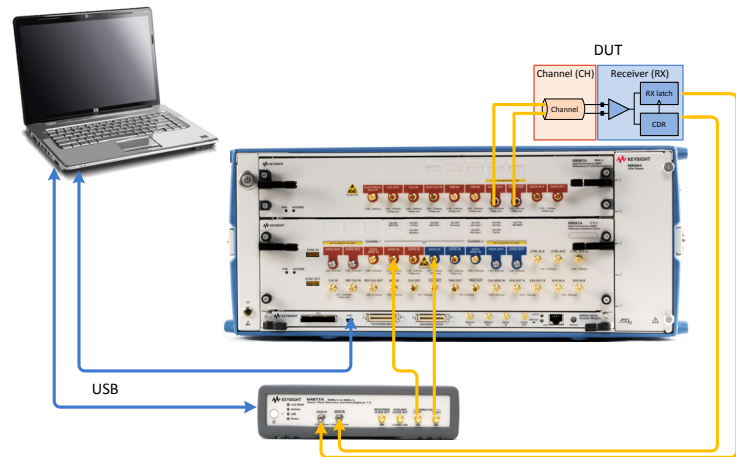

Figure 27 M8061A, M8041A and N4877A (Demux mode) setup example

Figure 28 on page -65 shows a basic setup using the M8061A multiplexer with the M8041A module in **Mux and Demux** mode. The M8061A expands the data rate up to 32 Gb/s and provides integrated and calibrated 4-tap de-emphasis (expandable to 8 taps).

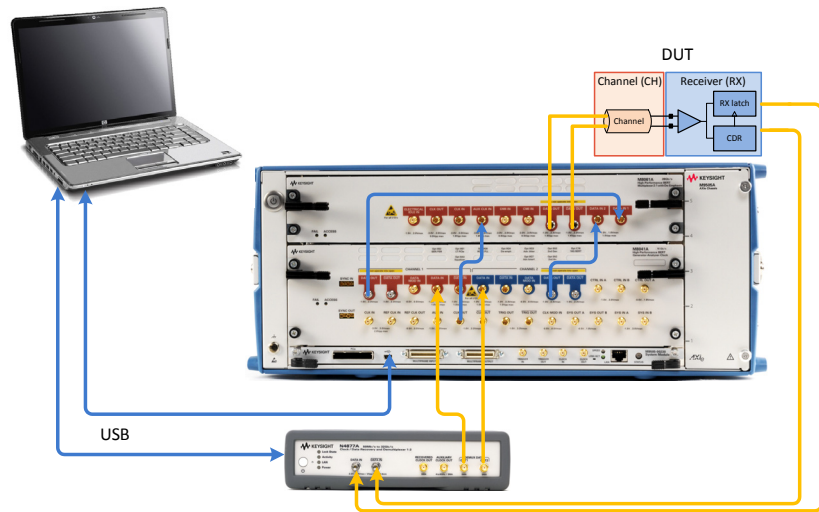

Figure 28 M8041A, M8061A and N4877A (Mux and Demux mode) setup example

Hardware Connections

Make the hardware connections as described below:

- Connect the M9505A AXIe chassis to the laptop via the USB micro-to-A cable.
- Connect the N4877A CDR/DMX (if present) to the laptop via the USB A-to-B cable.
- Connect M8041A Channel 1 DATA OUT to M8061A DATA IN 1 with a triplet phase-matched cable (PN: M8061A-804).
- Terminate M8041A Channel 1 /DATA OUT.
- Connect M8041A Channel 2 DATA OUT to M8061A DATA IN 2 with a triplet phase-matched cable (PN: M8061A-804).
- Terminate M8041A Channel 2 /DATA OUT.
- Connect M8041A CLK OUT to M8061A AUX CLK IN with a triplet phase-matched cable (PN: M8061A-804).
Insert the M8061A-802 or M8061A-803 clock filter between these connectors, which will dramatically decrease the intrinsic RJ of the output when bitrates are >25Gb/s.
- Terminate M8041A /CLK OUT

M8061A Output to Single-ended DUT Connection

Connect the M8061A output to a DUT and then to the N4877A as described below:

- Connect M8061A DATA OUT to DUT DATA IN.
- Connect M8061A /DATA OUT to DUT /DATA IN with a phase-matched cable, or alternately terminate the M8061A /DATA OUT as shown (single-ended configuration).
- Connect DUT DATA OUT to N4877A DATA IN.
- Connect DUT /DATA OUT to N4877A /DATA IN with a phase-matched cable for best results, or alternately terminate the DUT /DATA OUT and leave the N4877A /DATA IN unterminated.
- Connect N4877A DEMUX DATA - OUT1 to M8041A Channel 1 DATA IN.
- Terminate M8041A Channel 1 /DATA IN.
- Connect N4877A DEMUX DATA - OUT2 to M8041A Channel 2 DATA IN (this does not need to be phase-matched to the cable used for channel 1).
- Terminate M8041A Channel 2 /DATA IN.

Figure 29 on page -67 shows the proper connection from the M8061A output to a DUT in a single-ended configuration.

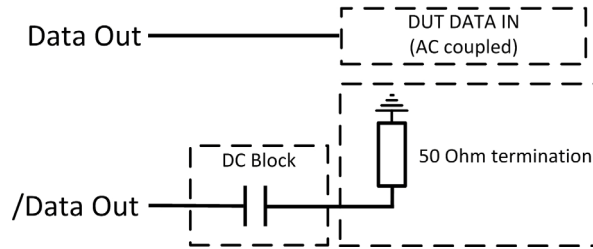

Figure 29 M8061A to DUT connection (single-ended)

NOTE

The M8061A /Data Out must be terminated to ensure proper performance.

M8061A Output to Scope Input Connection

Connect the M8061A output to a scope (non 50 Ohm input) as described below:

- Connect M8061A DATA OUT to scope input.
Figure 30 on page -68 shows the proper connection from the M8061A output to a scope input (non 50 Ohm input).

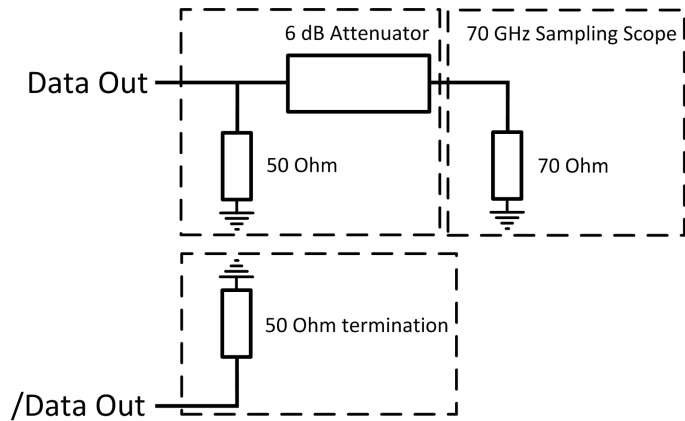

Figure 30 M8061A to scope connection

- Connect M8061A /DATA OUT to a 50 Ohm termination.
- If necessary, remove termination and connect M8041A /CLK OUT to scope.

NOTE

The M8061A /Data Out must be terminated to ensure proper performance.

M8061A Output to N4877A Connection

Connect the M8061A output to N4877A as described below:

- Connect M8061A DATA OUT to N4877A DATA IN.
- Connect M8061A /DATA OUT to N4877A /DATA IN with a phase-matched cable, or alternately terminate M8061A /DATA OUT as shown and leave the N4877A /DATA IN unterminated (single-ended configuration).

Figure 31 on page -69 shows the proper connection from the M8061A output to a the N4877A input in a single-ended configuration.

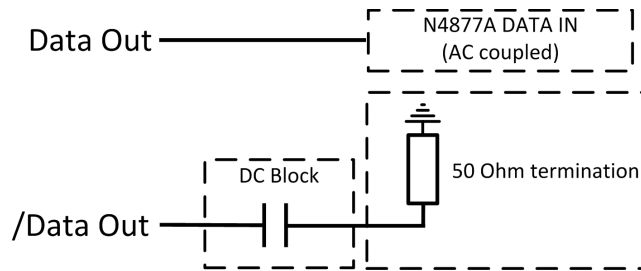

Figure 31 M8061A to N4877A connection

- Connect N4877A DEMUX DATA OUT1 to M8041A Channel 1 DATA IN.
- Terminate M8041A Channel 1 /DATA IN.
- Connect N4877A DEMUX DATA-OUT2 to M8041A Channel 2 DATA IN (this does not need to be phase-matched to the cable used for channel 1).
- Terminate M8041A Channel 2 /DATA IN.

NOTE

The N4877A /DATA IN is unterminated and the M8061A /Data Out must be terminated to ensure proper performance.

M8062A Setup Example (32 Gb/s)

Make the hardware connections as described in this section. The provided semi-rigid cable set (M8062-61641, M8062-61642 and M8062-61643) should be installed in the order listed below. The cables are labeled with corresponding port names for reference.

- 1 Connect the M9505A AXIe chassis to the laptop or PC via the USB micro-to-A cable.
- 2 Connect M8062A DATA OUT 1 to M8041A DATA IN CH 1 (PN: M8062-61641)
- 3 Connect M8062A DATA OUT 2 to M8041A DATA IN CH 2 (PN: M8062-61642)

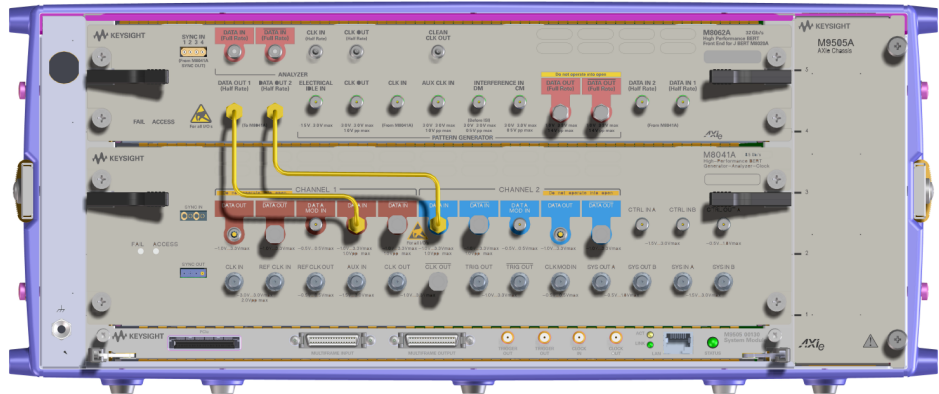

- 4 Connect M8062A CLK IN to M8041A CLK OUT (PN: M8062-61643-1)
- 5 Connect M8062A DATA IN 2 to M8041A DATA OUT CH 2 (PN: M8062-61641-2)

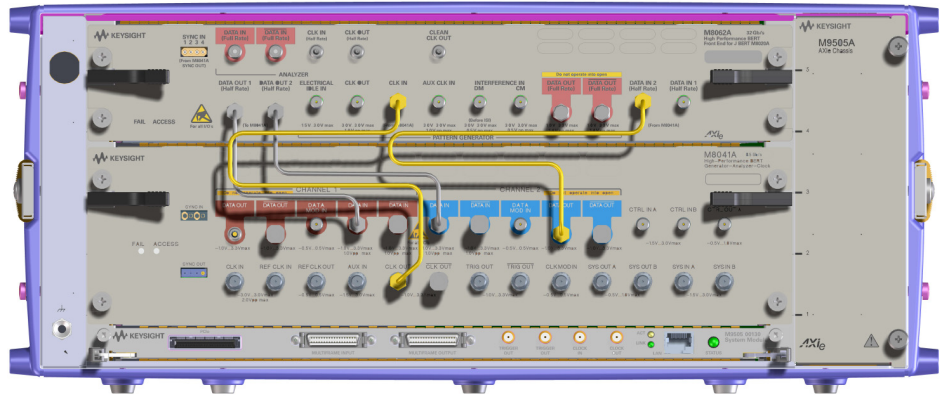

- 6 Connect M8062A DATA IN 1 to M8041A DATA OUT CH 1 (PN: M8062-61641-3)

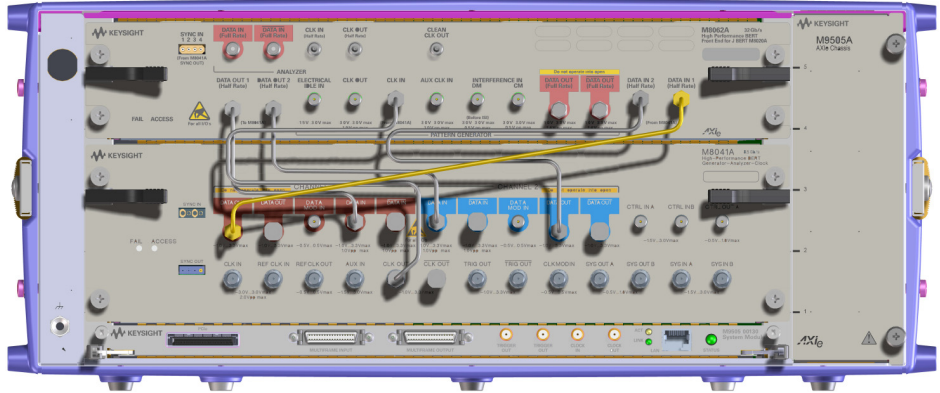

- 7 Terminate the following M8041A ports into 50-ohms: Channel 1 /DATA OUT, Channel 2 /DATA OUT, /CLK OUT, Channel 1 /DATA IN, Channel 2 /DATA IN.
- 8 Terminate the following M8062A ports into 50-ohms: DATA OUT and /DATA OUT.

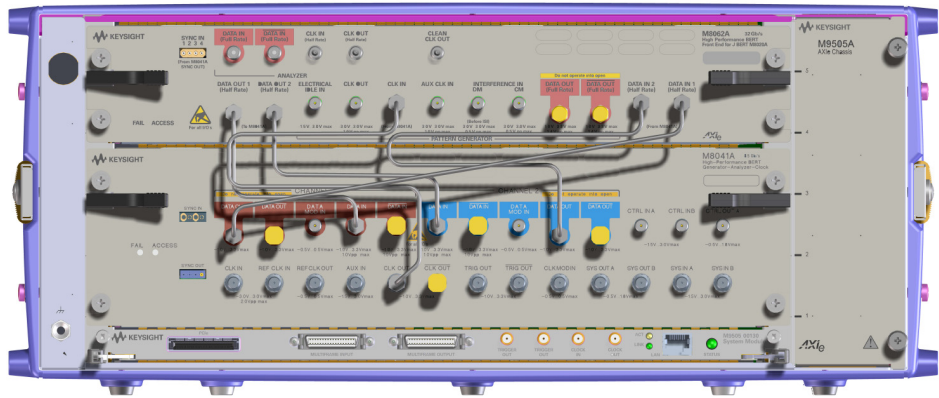

9 Connect M8041A SYNC OUT to M8062A SYNC IN

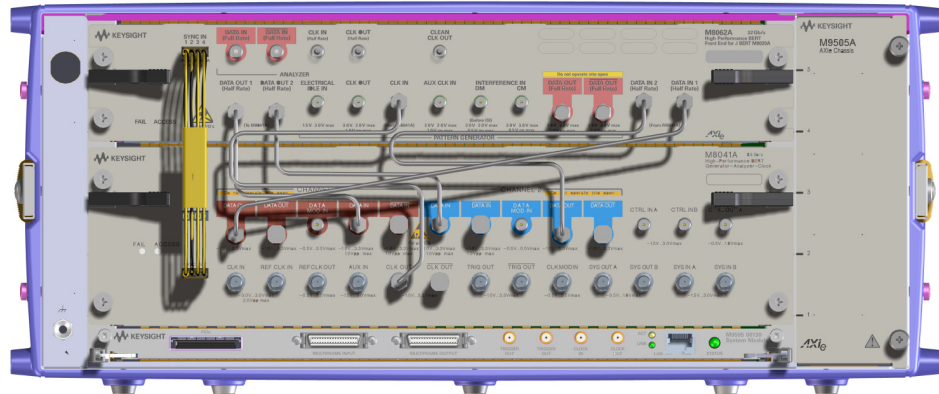

10 Torque the connectors at both ends of each cable to 0.9 N/m (8.0 in-lbs).

NOTE

While connecting a module which requires the sync cable connection (e.g. M8051A, M8062A) to the test setup, make sure to connect the sync cable after completing the other connections and also remove the sync cable first while disconnecting the connections.

3 Basic Setup for M8030A

Step 1 - Unpack the Shipment / 74

Step 2 - Install the Chassis / 75

Step 3 - Install the ASM in the Chassis / 76

Step 4 - Power-Up and Power-Down the Chassis / 76

Step 5 - M8030A Configuration / 77

Step 6 - Set up the Host PC (not required for M8030A-BU1) / 79

Step 7 - Power on the Chassis First then the Host Controller / 80

Step 8 - Verify Basic M8030A Operation / 81

Step 9 - Install Keysight IO Libraries Suite (not required for M8030A-BU1)
/ 82

Step 10 - Install M8070A Software (not required for M8030A-BU1) / 82

Step 11 - Install the Licenses / 83

Step 1 - Unpack the Shipment

The M8030A-BU1 or M8030A-BU2 is shipped with the modules pre-installed in the M9514A AXIe Chassis.

Unpack and verify the shipment contents to check if you have received all the items that you ordered. The shipment contents can vary depending on the options that you ordered. Therefore, the shipping list delivered with the shipment should supersede these lists.

Table 32 Typical contents of an M8030A instrument shipment

Item	Description
M8030A-BU1 or M8030A-BU2	The M8030A that you ordered. M8030A-BU1 - M9514A 14-slot AXIe chassis with embedded AXIe controller. Software is pre-installed on embedded controller. M8030A-BU2 - M9514A 14-slot AXIe chassis, does not include a PC, requires an external PC.
Accessories	The accessories will vary depending on the M8030A and the options that you ordered while purchasing the module. Accessories include standard items that are shipped with the M8030A as well as optional items that you ordered separately. (Please check the M8030A product data sheet for the latest list of default and optional accessories. Latest version can be downloaded from www.keysight.com/find/M8030a)
M8070A	CD-ROM with M8070A system software.
Start Here	Document which provides instructions to be followed before operating the M8030A Multi-Channel BERT.
Tips for Preventing Damage to M8020A and M8030A	Document which provides tips for preventing damage to M8020A and M8030A.
Getting Started Guide	This document, <i>Keysight M8020A and M8030A Getting Started Guide</i> . (Please check the Keysight website: www.keysight.com/find/M8030a for the latest guide.)
M8192A Multi-Channel Synchronization Module	For further information, please check the Keysight website www.keysight.com/find/m8192a for the latest version of related documents and data sheet.

Carefully inspect all items in the shipment for any damage.

Return the Damaged/Defective Item to Keysight for Repair/Replacement

If anything is missing, defective, or damaged,

- 1 Review the warranty information shipped with your product or check the warranty information on Keysight website.
 - To check the warranty information on your module, go to www.keysight.com/find/warranty and specify the module's model number (for example, M8041A) in the Product Number field, and specify the serial number from the top of the module in the Serial Number field.
- 2 Contact the nearest Keysight Sales Office. If you need assistance finding Keysight contact information, go to www.keysight.com/find/assist (worldwide contact information for repair and service).

Step 2 - Install the Chassis

If you have not already done so, please refer to the *Keysight M8020A and M8030A Installation Guide* for detailed installation instructions.

Product specifications, available accessories, firmware and software may change over time. Please check the Keysight website at www.keysight.com/find/M9514A for the latest updates to the product software, guides, data sheet and help files.

WARNING

Chassis exceeds 48 kg. Use a mechanical lift to lift the chassis. The chassis should be transported using a rolling cart. Do not lift the chassis by the handles on the front and rear of the chassis.

WARNING

Hearing protection must be worn when working on or around the chassis when it is powered on. The airflow noise around the chassis can exceed 79 dB(A). This is outside the range that is normally considered safe (70 dB(A)). Over and above that level is considered hazardous and can result in permanent hearing damage.

Step 3 - Install the ASM in the Chassis

Before powering on the chassis, install the M9521A AXIe System Module (ASM) in chassis slot 7. Please refer to the *Keysight M8020A and M8030A Installation Guide* for detailed installation instructions.

Step 4 - Power-Up and Power-Down the Chassis

This step ensures that the ASM is properly installed in the AXIe chassis and that the chassis and ASM power-up properly. It is not necessary to connect the chassis or ASM to a host computer for this step. After verifying that all of the chassis and ASM Status LEDs have turned solid green, please power-down the chassis.

To Power Up the Chassis

Ensure Circuit Breakers are Closed - Close all three rear panel circuit breakers (ON position).

Press Chassis On/Standby Button - Press the chassis' front panel ON/STANDBY switch. It will be dimly lit to indicate that AC power is available and the chassis is in the Standby mode; it will be brightly lit when depressed and the chassis is powered on.

The Status LEDs on the chassis and ASM cycle as follows:

- 1 Light off - with button in STANDBY mode
- 2 Green, blinking - for a few seconds after POST
- 3 Green, steady - successful chassis power-up is complete.

If either the chassis or the ASM do not power up to a steady green Status LED, or either powers up to a steady red Status LED, the chassis or ASM has detected a failure. Immediately power down the chassis.

If the chassis ON/STANDBY switch flashes continuously after turning on the chassis, press and hold the ON/STANDBY switch for five seconds. If this does not resolve the issue, power down the chassis. Refer to the *M9514A and M9521A Service Guide*.

To Power Down the Chassis

There are two power-down modes:

- For routine power-down or to cycle power to the chassis, momentarily press the chassis ON/STANDBY switch. The system does a controlled shutdown of the embedded controller (if installed) and instrument modules and then shuts down the power supply. The main chassis fans will gradually drop in speed to off. This is normal.
- If you press and hold the ON/STANDBY button for more than five seconds, the system shuts down the power supplies immediately.

Step 5 - M8030A Configuration

The M8030A is a modular test solution which can be tailored to your specific needs from two channels with one M8041A to up to 10 channels. The modules must be installed in the M9514A AXIe 14-slot chassis as described in [Table 33](#) on page -77:

Table 33 M8030A Modules Configuration

Slot Number	Module
# 1	M8030A-BU1 AXIe embedded controller.
# 2, 3 & 4	M8041A module
# 5 & 6	M8051A module
# 7	M9521A AXIe system module
# 8 & 9	M8051A module
# 10 & 11	M8051A module
# 12 & 13	M8051A module
# 14	M8192A multi-channel synchronization module

M8030A Modules Arrangement Example

Figure 32 on page -78 shows an example of modules arrangement in the M9514A AXIe 14-slot chassis.

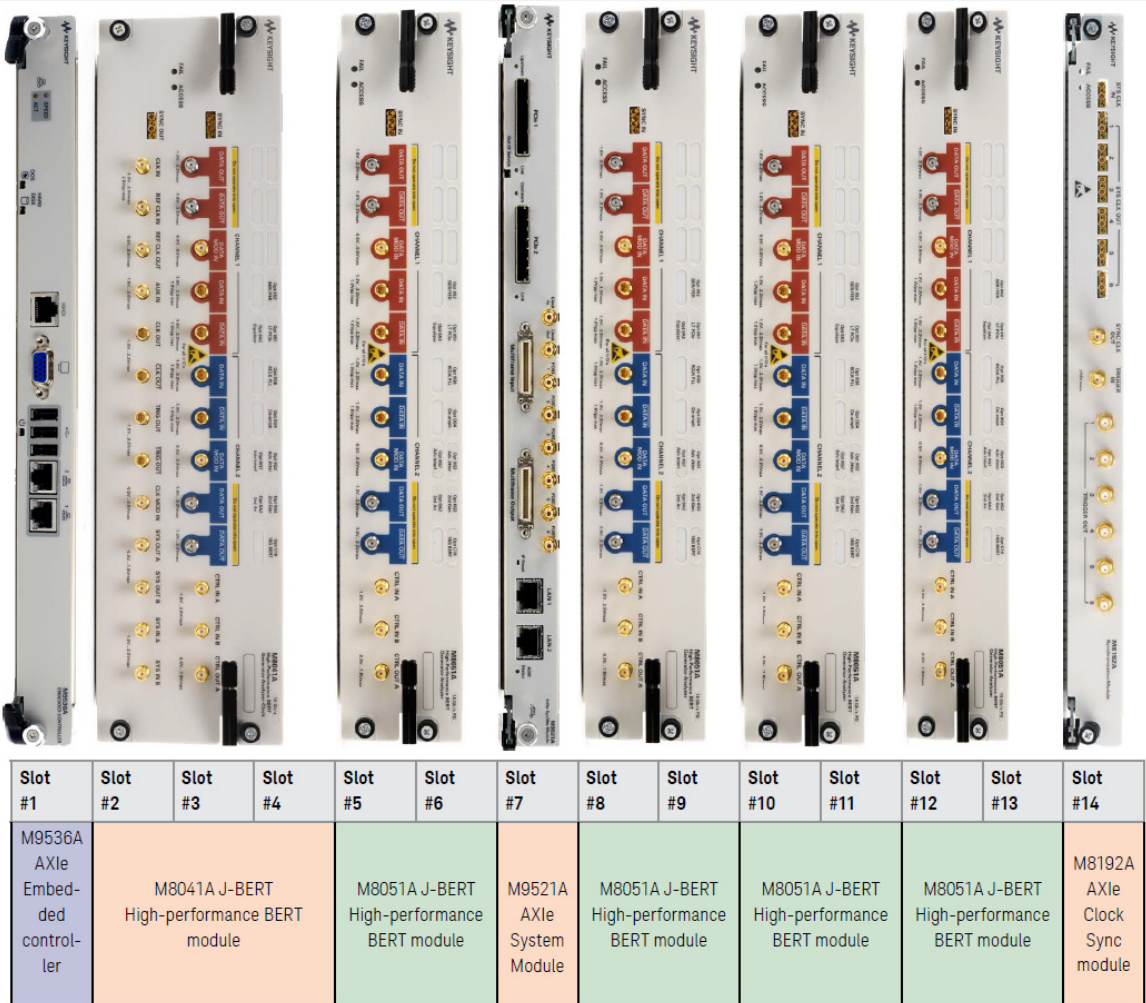

Figure 32 Example of M8030A module arrangement

Step 6 - Set up the Host PC (not required for M8030A-BU1)

Communication with the M9514A chassis, AXIe System Module (ASM) and installed instrument modules requires a host PC, a Windows based computer that may be:

An Embedded Controller (takes up slot one in the chassis). An AXIe embedded PC (also commonly called an embedded controller) such as the Keysight M9536A, allows for stand-alone test system operation. PCIe and LAN connections from PC to ASM are made directly at the chassis backplane.

A separate rack-mounted or desktop PC. To use the chassis PCIe data transfer capabilities, this external host PC must have an available PCIe x8 slot and BIOS support for proper enumeration of devices on the PCIe bus. PCIe connection from the host PC to ASM requires a PCIe adapter card and cable.

Keysight recommends use of a PC, card and cable tested with the AXIe mainframe; a current list can be found at:

www.keysight.com/find/axie-chassis.

Computer Hardware and Software Requirements

The following are the hardware and software requirements that should be met on the host computer before the installation of software components on this computer:

Hardware requirements

- Pentium® processor 1 GHz or equivalent
- 16 GB available RAM
- USB 3.0 connection
- PCIe 2.0/8x (only for highest data throughput and desktop PC)
- VGA resolution 1024 x 768
- 1.5 GB or more free hard disc space

Software requirements

- The following operating systems are supported:
 - Windows 7 (64 bit) SP1
 - Windows 8 (64 bit)
 - Windows 8.1 (64 bit)
- Keysight I/O libraries version 16.3 or higher

NOTE

The M8070A software is required to control the M8030A. M8070A-OTP or M8070A-ONP license is required for controlling hardware.

NOTE

PCIe connectivity between the M9514A AXIe Chassis and an external desktop PC controller is recommended when full channel plus large patterns need to be downloaded.

Step 7 - Power on the Chassis First then the Host Controller

Power up all the connected hardware components in the M9514A AXIe Chassis.

- 1 Press the ON/Standby button on the front panel of the chassis to power on the chassis.



Figure 33 Chassis ON/standby button

- 2 After powering up the chassis, wait until the Status LED of the ASM is solid green. This ensures that the PCIe channel in the chassis is ready for the successful connectivity of the chassis to the host computer.
- 3 Wait until the Access LED(s) of the module(s) in the chassis is/are solid green.
- 4 Power up the host computer. By this time, the Status LED of the ASM in the chassis and the Access LED(s) of the module(s) should have been steady green indicating a power ready status of the setup.

The step to power up the host computer is not required if you are using the M9536A AXIe Embedded Controller module as the host computer because it gets powered on simultaneously with the chassis through the chassis backplane.

NOTE

If you plan to connect the J-BERT M8030A to a corporate LAN and the M9536A AXIe Embedded Controller is installed, you must use the Ethernet port available on the M9536A AXIe Embedded Controller or the LAN port on the external PC.

NOTE

To power down a chassis, first turn off the host computer and then power down the chassis using the On/Standby button on its front panel.

If you are using the M9536A AXIe Embedded Controller module as the host computer, ensure that you first shut down the controller by executing the Windows shutdown process.

Do not use the circuit breaker for routine chassis turn off.

The module(s) are turned off automatically with the chassis.

Step 8 - Verify Basic M8030A Operation

After powering ON the connected hardware components, you can verify if you have correctly set up the hardware if:

- a steady green status light is displayed on the ASM of the M9514A AXIe Chassis indicating that the chassis has powered up successfully.
- the Access LED on the front panel of the instrument module turns on indicating that the module is in a power- ready state.
- the Out of Service (OOS) LED on the front panel of the M9536A AXIe Embedded Controller turns off. (Applicable only when you are using M9536A AXIe Embedded Controller as the host computer).

If the chassis does not power up to a steady green Status light, or powers up to a steady red light, the chassis has detected a failure and requires service.

If the Fail LED on the front panel of the instrument module is steady red and does not turn off, it indicates a power fault condition. In such a situation, the instrument module may require repair/service.

Contact your Keysight representative to replace or service the chassis/module.

Step 9 - Install Keysight IO Libraries Suite (not required for M8030A-BU1)

IO Libraries Suite version 16.3 or later is required. Always use the latest version of the Keysight IO Libraries.

NOTE

Perform this step if you are setting up an M8030A-BU2 system or the host computer you are using as part of the M8030A system requires I/O library installation.

- 1 Disconnect any devices connected to the host computer.
- 2 If open, close all applications on the host computer.
- 3 Insert the *Automation-Ready* CD in your CD-ROM drive or download and install the IO Libraries from www.keysight.com/find/iosuite.
- 4 Follow the instructions as prompted during the installation.
- 5 After installation, you will see the Keysight IO icon in the taskbar notification area of the host computer screen.

Step 10 - Install M8070A Software (not required for M8030A-BU1)

NOTE

Perform this step if you are setting up an M8030A-BU2 system or the host computer you are using as part of the M8030A system requires I/O library installation.

You will need to install the M8070A software and license file to control the M8030A.

NOTE

A CD-ROM is shipped when ordering the M8070A (part of the M8030A configuration).

To install the software

- 1 Insert the CD ROM into the host computer or download the latest M8070A software from www.keysight.com/find/M8070A.
- 2 Double-click the setup (.exe) file.
The InstallShield Wizard is displayed.
- 3 If displayed, click **Install** to continue or click **Next** if the system controller meets the minimum system configuration requirements displayed by the wizard.
- 4 When displayed, accept the license agreement and click **Next**.
- 5 Click **Install** to start the installation then follow any on-screen prompts/instructions.
- 6 In Windows click **Start > All Programs > M8070A Keysight > M8070A Keysight** to verify software installation. The Startup screen of the M8070A software should display.

Step 11 - Install the Licenses

NOTE

All M8030A-BU1 licenses have been pre-installed (except for a floating/networked license). All other system configurations require license installation as described in this step.

The M8070A software requires a license to communicate with the M8030A hardware. You either purchased an M8070A license to install on a dedicated host computer (M8070A-OTP) or one that can be installed on a network server that will be used as a license server for operation over a company network (M8070A-ONP, floating/networked).

In addition to the M8070A license, the M8030A, being a modular product, includes different sets of modules hosted in an M9514A AXI chassis. Each module has its own licenses corresponding to specific features. Module licenses are pre-installed at the factory according to the specific options that were ordered. For more detailed information about licensing, refer to the *M8070A User Guide*.

For more detailed information on how to install the license, refer to [Step 9 - Install the Licenses](#) on page 50.

Keysight J-BERT M8020A High-Performance BERT and
M8030A Multi-Channel BERT

Getting Started Guide

4

Using M8020A / M8030A

Locating Electronic Manuals and Online Help / 86

Routine Care / 86

Starting the M8070A Software / 87

Perform a Measurement / 88

M8061A/62A Configuration (Optional) / 96

Updating Software Components / 100

Locating Electronic Manuals and Online Help

Various electronic manuals and the *M8070A Online Help* provide information on how to configure and use the supported instrument modules.

On installing the M8070A software, you will find documentation by clicking **Start > All Programs > Keysight M8070A > Keysight M8070A Documentation**.

You can also visit www.keysight.com/find/m8020a to find the latest versions of various manuals and the data sheet for each M8020A module.

Routine Care

NOTE

Except for performing initial chassis verification or troubleshooting, do not operate the chassis with empty slots. Always insert a filler panel in empty slots. This is especially important for the slots on either side of an installed instrument module. This allows proper air flow and cooling, and provides EMI shielding for the chassis and installed components. Leaving slots empty can increase fan speed, raise ambient noise, overheat components, and can cause the module to shut down.

CAUTION

Do not block the vent holes on the chassis. This overheats and damages their components. Leave a gap of at least 2" (50 mm) around all vent holes.

CAUTION

The enclosure surface of the module may become hot during use. If you need to remove the module, first power down the AXIe chassis, allow the module to cool, and then pull the module out of the chassis.

NOTE

For preventing damage, for usage tips, and for ESD information, read and follow the instructions in the “*Tips for Preventing Damage to M8020A/M8030A*” (M8000-91010).

Starting the M8070A Software

- 1 Ensure that the system is powered up and ready to start as described in the sections [Basic Setup for M8020A](#) on page 41 and [Basic Setup for M8030A](#) on page 73.
- 2 On the host computer, click on **Start > All Programs > Keysight M8070A > Keysight M8070A**.
- 3 When the **Load Settings** screen appears as shown in [Figure 34](#) on page -87, load the last used, factor preset, or new settings.

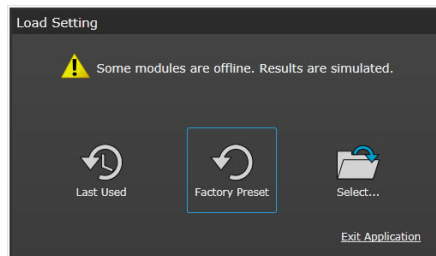

Figure 34 Load Settings screen

- 4 The screen shown in [Figure 35](#) on page -88 should now be displayed.

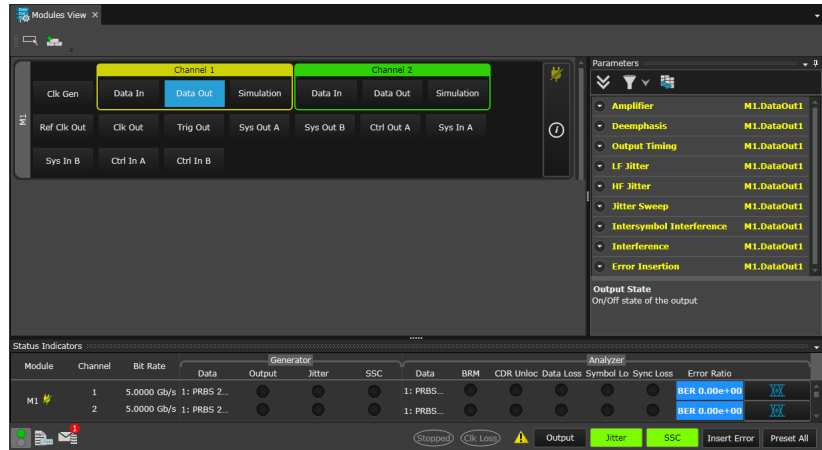

Figure 35 M8070A user interface

Perform a Measurement

The following measurement example verifies a BER of 0 in channel 1 of the M8041A.

- 1 Connect the M8041A Channel 1 Data Out to Channel 1 Data In.
- 2 In the M8070A software interface, set the data rate to 10 Gb/s as follows:
 - a Click on **System > System View**.
 - b Click on the **PLL Synthesizer Internal** block as shown in [Figure 36](#) on page -89 to display the **Synthesizer** properties.

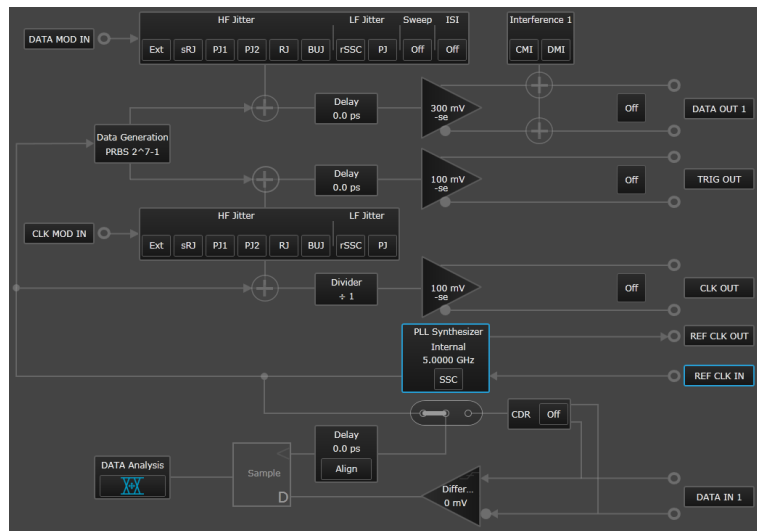

Figure 36 Synthesizer parameters

- c In the **Synthesizer** parameters, click in the numeric field corresponding to the **Frequency** setting.
- d Using the numeric keypad, enter **10** then click on the **GHz** button as shown in Figure 37 on page -89. If your system has a maximum data rate of 8 Gb/s, leave the frequency setting at 5 GHz.

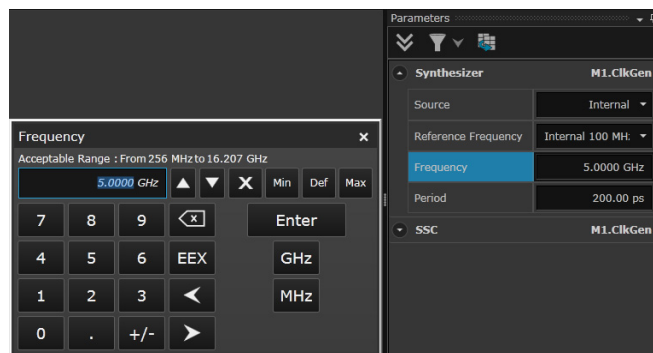

Figure 37 Set frequency to 10 GHz

- 3 Click on **Patterns** > **Sequence Editor**.
- 4 Click in the **Analyzer** block as shown in [Figure 38](#) on page -90.

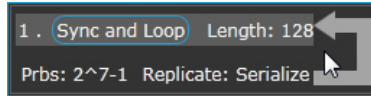

Figure 38 Analyzer controls

- 5 Expand **Block Data**.
- 6 Select a PRBS 9- 1 pattern as follows:
 - a In the **Block Data** properties, select **Prbs** as the **Pattern Type** as shown in [Figure 39](#) on page -90.

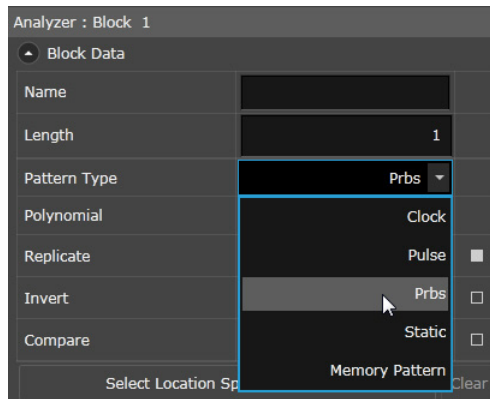

Figure 39 Select Pattern Type

- b In the **Block Data** properties, select **2⁹- 1** as the **Polynomial** as shown in [Figure 40](#) on page -91.

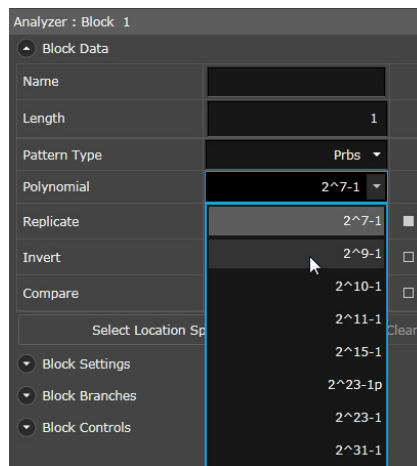

Figure 40 Select Polynomial

- c In the **Block Data** properties, click on the **Select Location Specific Patterns** button.
- d Select **M1.DataIn1** then click on the **Select** button as shown in [Figure 41](#) on page -91.

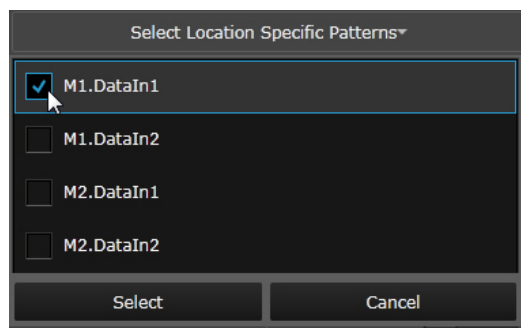

Figure 41 Select module/channel number

- e The **Analyzer** block should now display the setup information as shown in [Figure 42](#) on page -92.

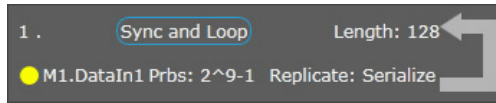

Figure 42 Analyzer setup information

- f Click on the **Download** icon to download the setup to the module as shown in [Figure 43](#) on page -92. After downloading, this icon turns green.



Figure 43 Download to module

- g Click in the **Generator** block as shown in [Figure 44](#) on page -92 and repeat this procedure to set up the pattern generator (M1.DataOut1).

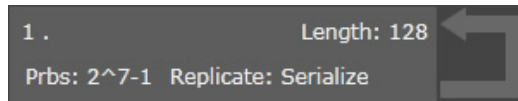

Figure 44 Select Generator block

- 7 Click on the **Modules View** tab.
- 8 Click on **Channel 1 > DataOut** corresponding to the M8041A (M1) as shown in [Figure 45](#) on page -92.

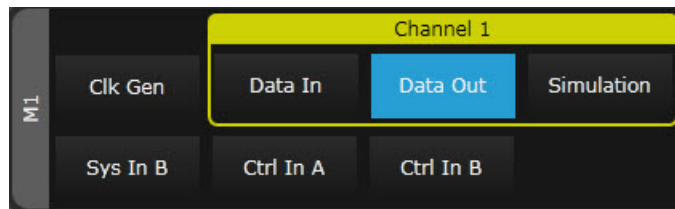

Figure 45 Select Channel 1 DataOut

- 9 Expand **Amplifier**.
- 10 Enable the output of the pattern generator by clicking on the **Output State** slider as shown in [Figure 46](#) on page -93.

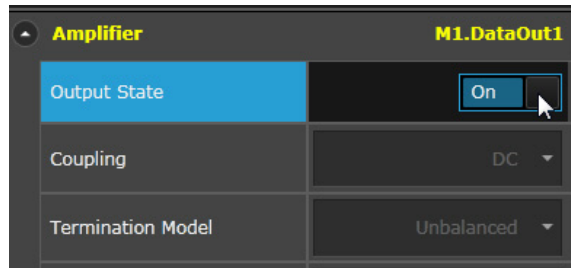

Figure 46 Enable pattern generator output

- 11 Enable the global outputs by clicking on the **Output** button present on the **Status Bar** as shown in [Figure 47](#) on page -93.

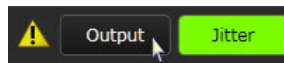

Figure 47 Enable global outputs

- 12 Click on **Channel 1** > **DataIn** corresponding to the M8041A (M1) as shown in [Figure 48](#) on page -93.

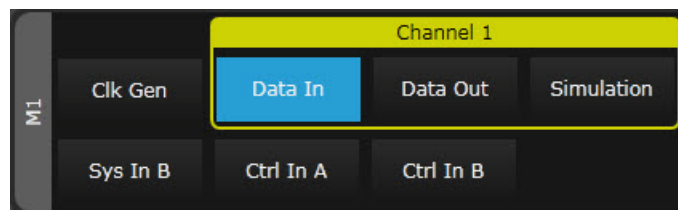

Figure 48 Select Channel 1 DataIn

- 13 Expand **Analyzer**.
- 14 Click on the **Alignment BER Threshold** button to synchronize and align the error detector as shown in [Figure 49](#) on page -94.

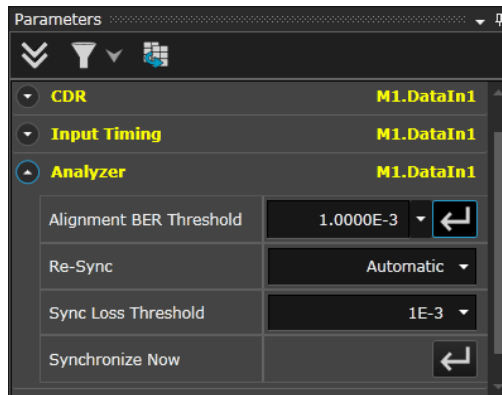

Figure 49 Alignment BER Threshold

- 15 At any time you can click on the **Hide Status Indicators Window** icon (bottom-left of display) to view/hide the module status including BER.
- 16 Click on **Measurements > Error Ratio**.
- 17 The default acquisition parameter settings are used as shown in [Figure 50](#) on page -94.

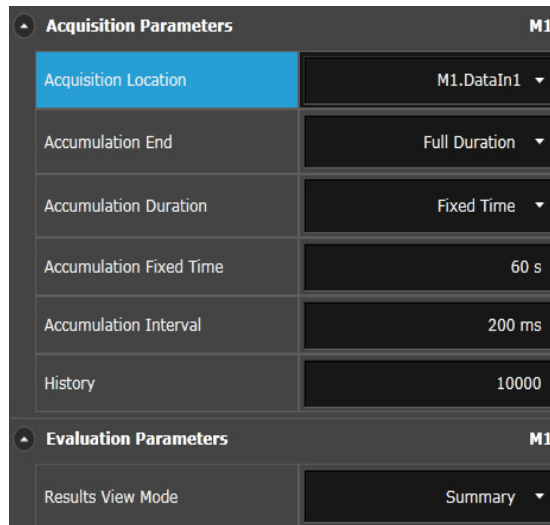

Figure 50 Acquisition parameter settings

- 18 Click on the **Start Measurement** button to start the measurement as shown in [Figure 51](#) on page -95.

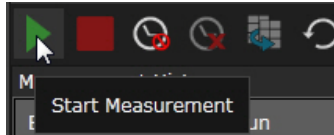

Figure 51 Start measurement

- 19 After the measurement has completed (60 sec), review the results shown below the graph in the **Calculated Results** table as shown in [Figure 52](#) on page -95.

Calculated Results				
Location	Show Graphics	Error Ratio	Compared Bits	Errored Bits
M1.DataIn1	<input checked="" type="checkbox"/>	0.00e+00	3.00e+11	0.00e+00

Figure 52 Calculated results

M8061A/62A Configuration (Optional)

M8061A Configuration

The following steps describe the procedure for M8061A configuration:

- Launch the M8070A software.
- Go to **Menu Bar > System** and then click **Module View**.
- Locate the **M8061A** module. The following figure shows an example of **Module View** when M8061A (M2) is connected with other M8020A modules:

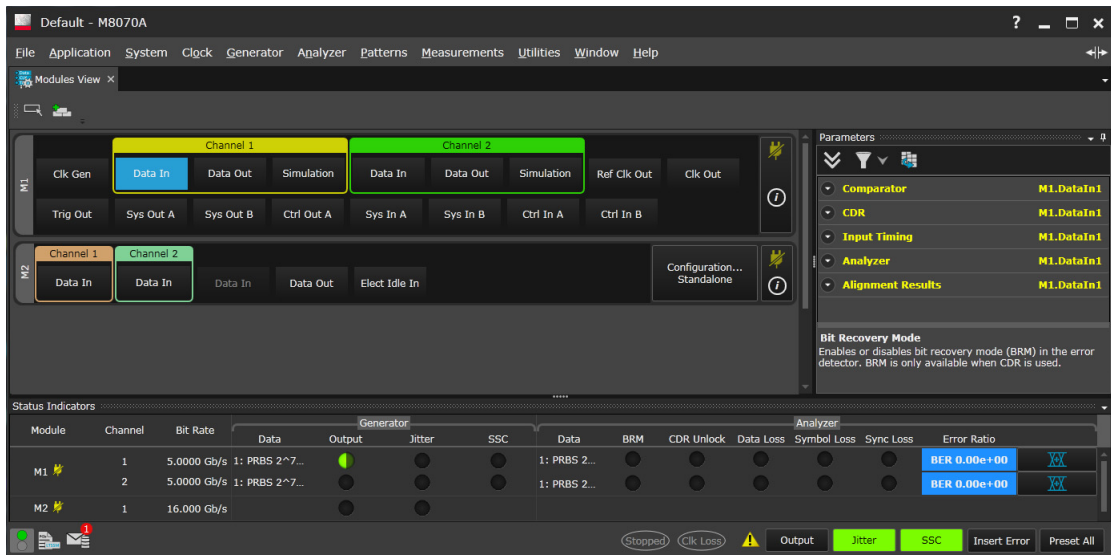

- Click **Configuration...** button present on the **M8061A** module.

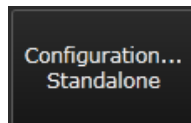

The **M8061A Configuration** dialog will appear as shown in the following figure:

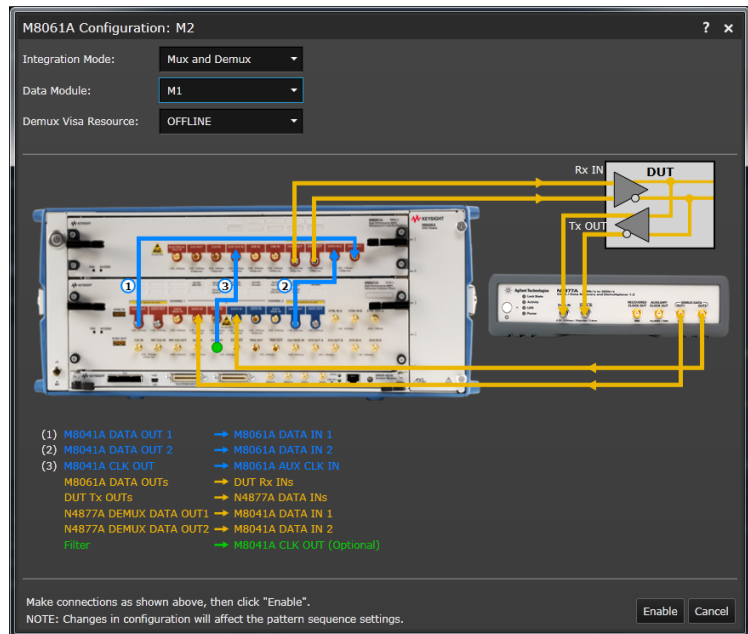

- Select the **Integration Mode**. The default mode is **Standalone Mode**. The other modes you can select are **Mux Only** mode, **Demux Only** mode and **Mux and Demux** mode.
- Select the **Data Module** to which the M8061A module is connected.
- Select the visa resource string for N4877A (Demux). This is required to connect N4877A instrument with M8020A.
- Click **Enable**. Depending upon the configuration settings, the ports which are used by the Data module and M8061A module will be disabled. For the block diagram representation and interactively modify the settings of the currently selected mode, switch to **System View**. For complete details, refer to the *M8070A User Guide* or *Online Help*.

M8062A Configuration

The following steps describe the procedure for M8062A configuration:

- Launch the M8070A software.
- Go to **Menu Bar > System** and then click **Module View**.
- Locate the **M8062A** module. The following figure shows an example of **Module View** when an M8062A (M2) and an M8041A (M1) are installed in the M8020A system:

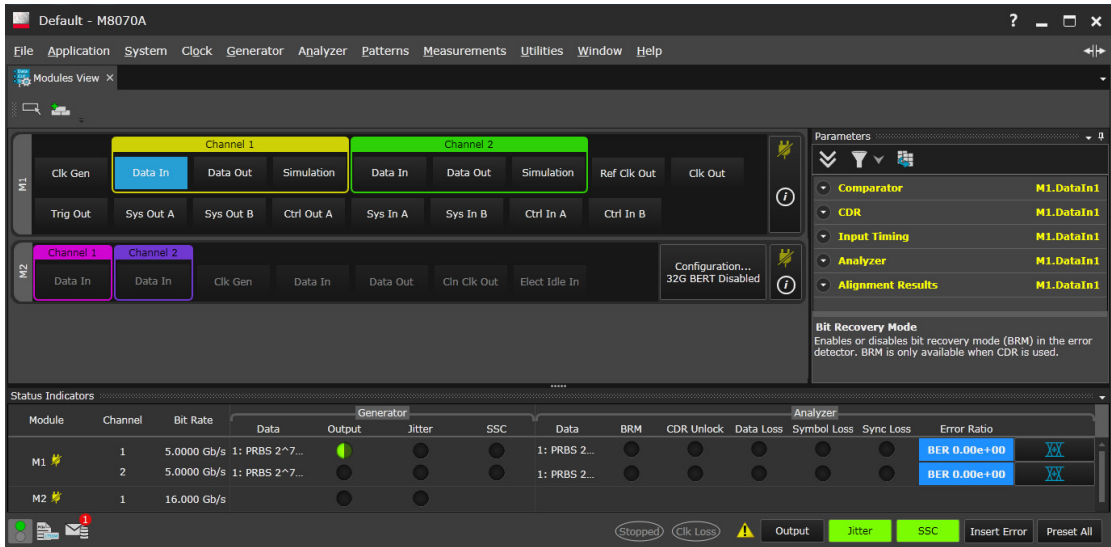

- Click **Configuration...** button present on the **M8062A** module.

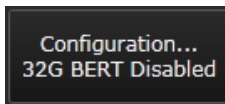

The **M8062A Configuration** dialog will appear as shown in the following figure:

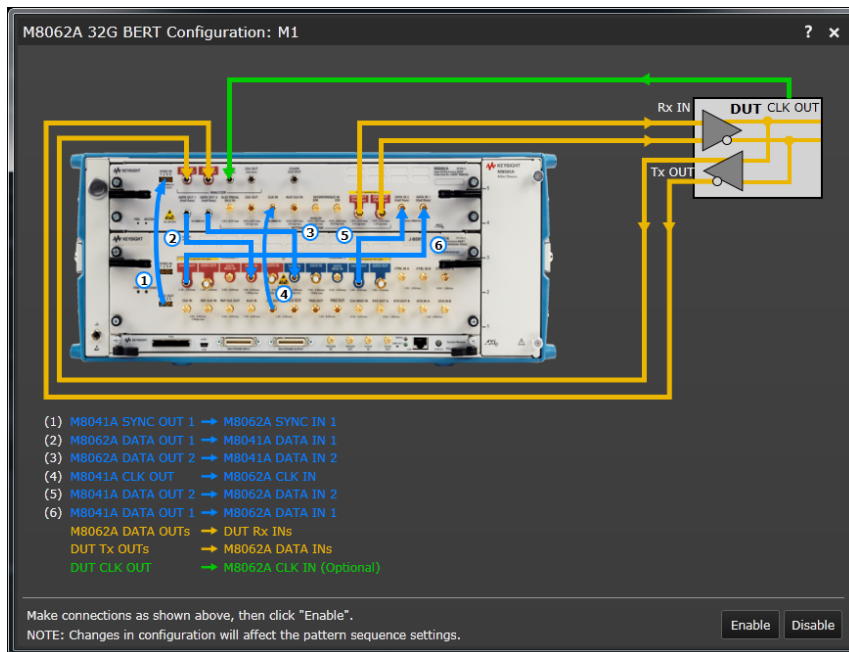

- Make the connections as shown in the above figure. The connection details can also be found at [M8062A Configuration](#) on page 98.
- Click **Enable**.

In the 32G mode, access to some M8041A user controls are disabled to facilitate software control of this configuration. For additional information, refer to the *M8070A User Guide* or *Online Help*.

Updating Software Components

Updated versions of the M8070A and module specific software components are available on the Keysight website.

These software components are available as .EXE files. To download a software upgrade:

- 1 Go to <http://www.keysight.com/find/m8070a>
- 2 Click the **Technical Support** tab.
- 3 Click **Drivers and Software**.
- 4 Type the model number of the instrument module for which software update is needed and click **Find**. Model number is located on the front panel of the module.
- 5 Click the **Driver and Software** link on the module page.
- 6 Download the required software update from the list of available updates.

Contacting Keysight Service and Support

To locate a sales or a service office near you, go to www.keysight.com/find/contactus

Quick Troubleshooting

This section lists the basic troubleshooting steps that you might find useful while setting up the M8020A.

The chassis does not power up

If the chassis or a module does not appear to power up, check the following:

- The circuit breakers at the rear of the chassis are set to the right, which is the ON position.
- The AC power cords are connected to a working power source.
- The electrical circuits are not overloaded. Check the combined power requirements of all equipment on the same circuit.
- There are no empty slots in the chassis. Leaving slots empty can overheat the inserted modules, causing them to shut down.

A module is exceptionally hot

- Check that the vent holes on the chassis are not blocked.

- Check that a filler panel module or an instrument module is installed into empty slots on either side of an instrument module.

The host computer is not getting connected to the chassis via PCIe

- Install the instrument module in the chassis before trying to connect the host computer to the chassis via PCIe. In the absence of an installed module, an attached host computer will not be able to connect to the chassis successfully.
- While powering up or restarting the host computer, make sure that you first power up the chassis, wait until the LED turns solid green, and then power up the host computer. This sequence is needed for the PCIe channel in the chassis to be ready for successful PCIe connectivity between the host and chassis.
- Windows may have failed to load the NIC drivers. This results in the display of the NIC driver install dialog. If this situation occurs, exit the NIC driver install dialog and install the NIC driver manually to achieve PCIe connectivity between the chassis and host computer.

The Keysight AXIe Embedded Controller module performs poorly and the operating system seems sluggish

This can happen if there are multiple hosts trying to communicate with the chassis at once. In such a situation, the module's embedded operating system is affected by a low-level driver resource conflict.

To resolve this, ensure that there are no external remote host computers still connected to the chassis and running.

Index

Numerics

5-slot AXIe chassis, [14](#)

A

ASM, [76](#)

Aux Clk In, [34, 38](#)

AXIe chassis, [14, 18, 76](#)

B

BER measurement example, [88](#)

C

circuit breaker, M9505A, [46](#)

Clean Clk Out, [37](#)

Clk In, [25, 34, 38, 39](#)

Clk Mod In, [25](#)

Clk Out, [25, 34, 38, 39](#)

CMI In, [34, 38](#)

Ctrl In A, [26, 30](#)

Ctrl In B, [26, 30](#)

Ctrl Out A, [26, 30](#)

D

Data In, [25, 29, 34, 38](#)

Data Mod In, [25, 29](#)

Data Out, [25, 29, 34, 38](#)

Demux Only, [97](#)

DMI In, [34, 38](#)

DUT setup, [61](#)

E

Electrical Idle In, [33, 37](#)

Embedded Controller, [79](#)

Embedded Controller Module, [16](#)

Embedded System Module, [15](#)

F

Features

M8041A, [22](#)

M8051A, [27](#)

M8061A, [31, 35](#)

H

host computer types, [40](#)

host computer, hardware/software requirements, [44, 79](#)

host computer, set up external, [43](#)

I

insertion/extraction handles, [23, 33, 37](#)

Integration Mode, [97](#)

IO Libraries, install, [49, 82](#)

L

labels, option, [60](#)

LAN connection, [16, 20](#)

LEDs

Access, [24, 28, 33, 37](#)

Aux In, [24](#)

Clk In, [24](#)

Clk Out, [24](#)

Ctrl In A, [24, 29](#)

Ctrl In B, [24, 29](#)

Ctrl Out A, [24](#)

Data In, [24, 28](#)

Data Mod In, [29](#)

Data Out, [24, 29](#)

Delay Mod, [24](#)

Delay Mod In, [24](#)

Fail, [24, 28, 33, 37](#)

Ref Clk In, [24](#)

Ref Clk Out, [24](#)

Sys Ctrl In A, [24](#)

Sys Ctrl In B, [24](#)

Sys Out A, [24](#)

Sys Out B, [24](#)

Trig Out, [24](#)

license, install M8070A-OTP, [51](#)

M

M8030A Modules Arrangement, [78](#)

M8030A Multi-Channel BERT, [74](#)

M8030A-BU1, [74](#)

M8030A-BU2, [74](#)

M8041, [14](#)

M8041A, [17](#)

M8041A components, [23](#)

M8041A features, [22](#)

M8051A components, [27](#)

M8051A features, [27](#)

M8061A components, [32, 36](#)

M8061A Configuration, [96](#)

M8061A Configuration dialog, [97, 99](#)

M8061A features, [31](#)

M8062A, [14, 35](#)

M8062A Module Components, [36](#)

M8070A license transport, [60](#)

M8070A Software, install, [50, 83](#)

M8070A Software, starting, [87](#)

M8070A-ONP license, [52](#)

M8070A-OTP license, [51](#)

M8092A, [17](#)

M8192A, [40](#)

M9505-00230, [15](#)

M9505A, [14](#)

M9505A, power down, [61](#)

M9505A, power up, [46](#)

M9514A AXIe Chassis, [74](#)

Index

M9536A, [16](#), [20](#), [79](#), [80](#)
measurement example, BER, [88](#)
Module Insertion/Extraction
Handles, [28](#)
module licenses, install, [59](#)
modules, [14](#)
Mux and Demux, [97](#)
Mux Only, [97](#)

O

operation, verify, [48](#), [81](#)
option labels, [60](#)

P

PCIe connectivity, [15](#), [18](#), [45](#)
PCIe, power up process, [47](#), [80](#)

R

Ref Clk In, [25](#)
Ref Clk Out, [25](#)
retaining screws, [23](#), [28](#), [33](#), [37](#)

S

safety summary, [3](#)
Standalone Mode, [97](#)
Supported Modules
M8051A, [14](#), [17](#)
M8061A, [14](#)
Sync In, [25](#), [29](#)
Sync Out, [25](#)
Sys In A, [26](#)
Sys In B, [26](#)
Sys Out A, [26](#)
Sys Out B, [26](#)

T

transport M8070A license, [60](#)
Trig Out, [25](#)

U

USB connectivity, [15](#), [18](#), [45](#)

